

IRP6+

INFRARED EXTENDER SYSTEM— IR MAIN SYSTEM UNIT

Introduction

An infrared (IR) extender system enables you to control your IR remote controlled A/V equipment from a remote location. This enables you to place your A/V components out of sight (behind cabinet doors, in the rear of a room, or in a different room) and still conveniently control your equipment.

The model **IRP6+** is an IR Main System Unit. It is one of three elements that make up an infrared extender system:

1. **IR Sensors** receive IR commands from hand-held remote controls and relay the commands to the Main System Unit via a 2-conductor shielded cable. Generally, sensors

are placed so that you can easily and naturally point your remote control directly at them. Niles offers an array of easily concealable sensors: wall-mount, ceiling-mount, surface-mount and table-top. IR sensors are the “eyes” of the system.

2. The **IR Main System Unit** provides a connection hub for the IR sensors and the IR flashers and is generally located near the A/V components. The IR Main System Unit’s level controls and LED indicators enable you to calibrate and troubleshoot an IR extender system. The Main System Unit is the “heart” of an IR extender system.

3. **Infrared Flashers** transmit the infrared signals from the IR Main System Unit to your A/V components. Niles manufactures flooding flashers (model IRC-1) and miniature “pin-point” flashers (model IRC-2).

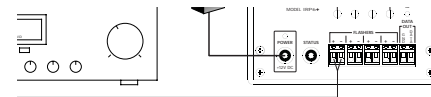

Remotely Located IR Sensors

Figure 1

IR Remote Controllable Stereo Receiver

DC Power Supply

IRP6+

Six remotely located IR Sensors are connected to an IRP6+. One IR Flasher, connected to the IRP6+, is transmitting an IR command to the Receiver’s IR sensor. The IRP6+ enables you to connect up to eight Niles IRC-1 Flooding Flashers and up to sixteen Niles IRC-2 MicroFlashers. The IRP-6+ is powered by plugging into an unswitched AC outlet.

Features and Benefits

The IRP6+ offers a number of improvements over other IR Extender Main System Units:

- Universal system—compatible with virtually all brands of A/V equipment and remote controls (the only exceptions are those brands using carrier frequencies higher than 64kHz).
- Exclusive Niles short-circuit protection provides for easy installation.
- Accommodates six IR sensors or keypads.
- Provides four low-distortion, high-current, variable-power Mosfet IR

Flasher outputs

- Red “Power” L.E.D. enables you to test for proper power supply operation and shorts between + (positive) and GND (ground) on your sensor connections.
- Green “IR” Test L.E.D. enables you to test for proper operation, interference, and for shorts between + and DATA on your sensor connections.
- Built-in “Status” generator broadcasts the amplifier “on/off” power status over existing IR wiring to provide power status display

when used with other Niles products like the IntelliPad that feature status display LED’s.

- Screw connectors simplify installation.
- Printed circuit board design assures high reliability.
- Two year parts and labor warranty.
- Proudly made in the USA.

Installation Considerations

Placement of the IRP6+

Place the IRP6+ conveniently close to the equipment it will be controlling. Generally, the unit is placed in a concealed location because its controls and indicators are only used during installation.

IMPORTANT: Do not place the IRP6+ on top of or directly behind a television set. Some television sets produce intense electromagnetic interference which may disable your IR extender system.

Wiring

From every IR Sensor location you must "home-run" a cable back to the IRP6+. Home run means that an individual cable is connected between each IR Sensor and the IRP6+. See Figure 3.

IMPORTANT: Avoid locating any of the cables, Sensors, Keypads or the Main System Unit near any potential sources of Electromagnetic Interference (EMI), such as light dimmers, speed controls for ceiling fans, electrical ballasts, television sets, large motors, heaters or air conditioners.

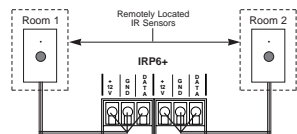
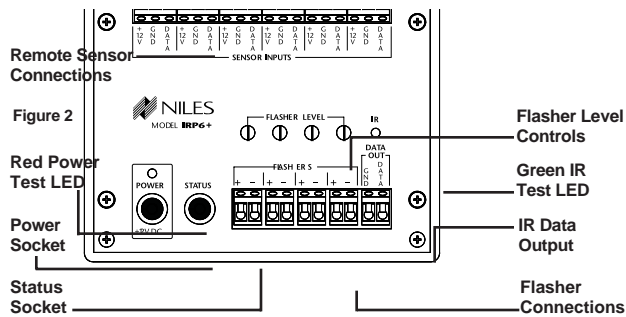

Figure 3

Installation

Before you begin, make sure that the sensor/keypad cables, the flasher cables and the 12v DC power supply cable will all reach the proposed location of the IRP6+. Mark the cables with labels describing where the cable originates (rather than which terminal on the IRP6+ it should connect to).

For proper installation, follow the steps outlined in the correct order. If you discover a fault in the course of installation, go on to the Troubleshooting Guide before continuing with the next installation step.



Keypad Wiring

When you are placing both a keypad and a sensor (or two keypads) in one room you may "daisy-chain" using a single cable. A cable is run between the keypad and the sensor and a single cable is run from either the sensor or the keypad back to the IRP6+. See Figure 4.

Sensor/Keypad Cable

The IRP6+ connects to IR sensors and keypads with 2-conductor shielded cable. Recommended cables are "data grade" cables made of two 22 gauge (or larger) conductors surrounded by a foil shield and a bare drain (ground) wire. Data grade cable provides the capability for runs

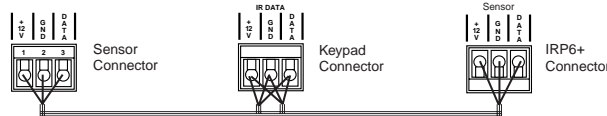

Figure 4

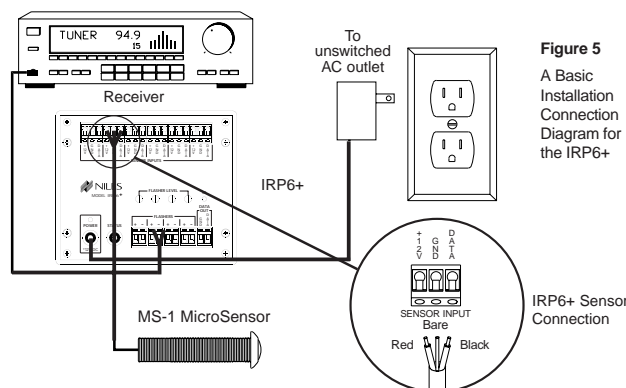

Figure 5

A Basic Installation Connection Diagram for the IRP6+

of up to 500 feet to each sensor. Examples are West Penn D291, Belden 8761 or Carol C 2516. Any 22 to 16 gauge 2-conductor shielded cable available at a hardware store will accommodate 150 foot runs to each sensor.

CAUTION: Do Not use un-shielded cable between any remote IR sensor or keypad and the IRP6+.

Flasher Cable

Niles infrared flashers come supplied with a 10 foot 2-conductor 22 gauge cable. Should you need to extend it, use a 16 gauge 2-conductor cable ("zip-cord"). Shielding is not necessary for a flasher. Flasher wires can be extended up to 200 feet.

Installation continued

STEP	DESCRIPTION
1. Connect and test the power supply. If it tests OK, unplug the connector from the power socket and proceed.	<p>A) Plug the supplied 12v DC power supply into an unswitched 120v AC outlet.</p> <p>B) Plug the connector into the socket marked "Power" on the IRP6+.</p> <p>C) If the Power LED does not light, test the unswitched 120v AC outlet with another appliance. If the outlet tests OK, you have a defective power supply which must be replaced for you to continue.</p>
2. Connect the first Sensor/ Keypad cable to either one of the Sensor inputs.	<p>A) Strip 1/4" of insulation from the wire ends of the cable.</p> <p>B) Attach the exposed wire ends to the appropriate connector. Be careful to prevent a filament of wire from shorting out two connectors. Red = +12v Bare = GND Black = DATA</p>
3. Test for shorts and interference.	<p>A) Reconnect the power supply. If the Power LED lights and the IR Test LED stays off, unplug the connector from the power socket and proceed to Step 4. The following LED conditions show a fault:</p> <ul style="list-style-type: none"> • If Power LED is Off there is a short between +12v and GND • If IR Test LED is On or Flickers there is a short between DATA and GND or Interference is present. <p>Before you proceed to Step 4 consult the Troubleshooting Section</p>
4. Connect the flashers to the flasher outputs. If you need to extend the wire, use a 2-conductor 16 gauge or larger (See Tech Tip on page 6).	<p>Route the connecting 2-conductor wire to the IR Main System Unit. Connect the ends of the wire to the corresponding positive and negative terminals labeled "Flasher" on the IRP6+.</p> <p>BE SURE TO OBSERVE PROPER POLARITY WHEN CONNECTING OR EXTENDING THE FLASHER WIRE.</p> <p>IRC-1: the wire lead marked with a gray stripe is negative (-); the unmarked lead is positive (+).</p> <p>IRC-2: the silver colored wire lead is negative (-); the copper colored wire lead is positive (+).</p>
5. Connect multiple flashers to a single output by connecting in series.	<p>Use crimp caps, wire nuts or solder to connect the negative of one flasher to the positive of the next flasher as shown to create a "series" circuit.</p> <p>IRC-1 Flooding Flasher Allows a maximum of TWO in series.</p> <p>IRC-2 MicroFlasher Allows a maximum of FOUR in series.</p>

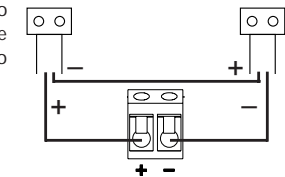
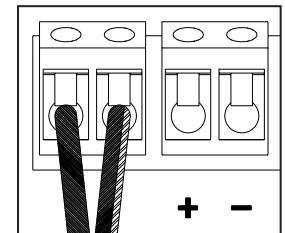

Testing the IR Extender System

Test your IR Extender system by following the three principal guidelines:

- All components can be operated.** Test all of your remote controls for all of your equipment.
- Operation is consistent.** A good test is to repeatedly step from Pause to Play with your VCR, CD, Laser

Disc, or Tape player remote control. Operation should be identical to standing in front of the component with the remote control pointed directly at the sensor window.

3. Maximum Range between the Remote Control and the Niles IR Sensor is similar to the maximum

range between the Remote Control and the A/V component's IR sensor. Typically a remote control with two batteries will have a 15 to 20 foot range and a remote with four batteries will have a 20 to 30 foot range.

Troubleshooting Guidelines

There are four basic problems which prevent proper operation of your IRP6+. In the order of probability, the problems are as follows:

Bad Connections or Wiring

If the connections or wiring are wrong, loose, shorted or open the system will not operate properly. The symptoms could include: Power LED flickers or is off, IR Test LED is continuously flickering or on without any remote control use, intermittent operation or no operation.

Steps (3) and (4) test your power supply connections.

Steps (13) thru (14), (23) thru (25) test your Sensor connections.

Steps (15) thru (18) test your Flasher connections.

Steps (26) and (27) tests your cable for shorts and opens.

Flasher Level is Too High

Many audio/video component's sensors are overloaded by receiv-

ing too strong of an IR command from the flasher. Symptoms can include: popping and clicking sounds from the speakers when a button is pressed on the remote control, poor IR receiving range, intermittent operation or no operation.

Step (15) provides detailed instructions on setting the proper flasher level.

Optical or Electromagnetic Interference

Sunlight, reflections, neon signs and other sources of infrared light or television sets, light dimming controls and other sources of electromagnetic fields can induce noise and interference into your IR extender system. Symptoms can include: flashback LED's continuously flickering or on without any remote control use, poor range, intermittent operation or no operation.

Steps (32) through (38) troubleshoot interference problems.

Optical Feedback Loop

If you have an IR sensor in the same room as a flasher, and you have some low-level noise or interference, an optical feedback loop can occur which will interfere with proper operation. Symptoms can include: poor range, intermittent operation or no operation.

Steps (19)through (22) provide instructions for eliminating optical feedback loops.

Start from Step One

In your installation you may be faced with a combination of the four problems or symptoms that are universal to all of the problems. Rather than trying to guess which problem you have, use a process of elimination. The Troubleshooting section is designed to eliminate the most common problems first. If you start from Step 1 and methodically check everything you will find the problem in much less time than the troubleshooter who makes assumptions.

Troubleshooting Guide

1) Test Remote Control

Verify that the remote control works by operating the equipment directly. If the remote does not operate your system directly, replace the batteries of the remote control. Replace the remote control if necessary.

2) Flasher Positioning

Flashers operate line-of-sight; be sure they are unobstructed and aimed at the front panel sensor windows of your components.

3) 12v DC Power Supply

Test that the red IRP6+ power LED is on when the wall adapter is plugged into an unswitched AC outlet.

- **Power LED On:** Go to Step 13
- **Power LED Off:** Go to Step 4

4) Disconnect Sensors

If the power LED does not light, disconnect all sensors and retest the power supply.

- **Power LED On:** Go to Step 6

- **Power LED Off:** Go to Step 5

5) Replace Power Supply

Either your power supply or your IRP6+ is defective. If you have another 12v DC power supply, first check that it has the same polarity (+ on the tip, GND on the sleeve). Plug the new power supply in and observe the Power LED.

- **Power LED On:** Retest System per **Testing the IR System** section on previous page
- **Power LED Off:** Return IRP6+ to your local Niles dealer for testing

6) Test Sensor Input 1

Reconnect one of the sensor cables. Re-test; plug the power supply back in and observe the Power LED.

- **Power LED On:** Go to Step 7
- **Power LED Off:** Go to Step 8

7) Test Sensor Input 2

A) If you DO NOT have a second sensor/keypad, Go to Step 12.

B) If you DO have another sensor/keypad, connect it to the second sensor input and re-test.

- **Power LED On:** Go to Step 12
- **Power LED Off:** Go to Step 8

8) Short between +12v (positive) and GND (ground).

Examine the connectors for a hair-like filament of wire between any of the contacts **at the IRP6+ and at the sensor or keypad**. Then retest.

- **Power LED On:** Go to Step 12
- **Power LED Off:** Go to Step 9

9) Test the Cable for Shorts

Disconnect the cable at both ends (at the sensor and at the IRP6+) and test it for shorts. Use an ohm meter or electrical continuity checker. You should read an open (Infinite Ohms) between Red and Bare, Red and Black or Bare and Black.

- **Short in Cable:** Replace cable
- **Cable tests OK:** Go to Step 10

Troubleshooting Guide continued

10) Replace the IRP6+

If you have another IRP6+, replace the one in the system and retest, if not go to Step 11.

11) Replace the Sensor or Keypad

If you have another Sensor or Keypad, exchange it and retest the system, otherwise return the IRP6+ and the sensor/keypad(s) to your local Niles dealer for testing.

12) System suddenly seems to be OK again.

The connections were poor and by touching and inspecting them you have changed their condition. Jiggle and tug on the wires and recheck the connections. If they all seem secure, retest the entire system per the Troubleshooting Guidelines.

13) IR LED without any IR input.

Observe the green IR Test LED on the IRP6+ with the power supply plugged in and all sensors and flashers connected.

- **IR Test LED is On or is Flickering:** Go to Step 32
- **IR Test LED is Off:** Go to Step 14

14) IR LED with IR input.

Have someone watch the green IR LED on the IRP6+ while you aim a remote control at a remote sensor and press a button.

- **IR Test LED Flashes:** Go to Step 15
- **IR Test LED Off:** Go to Step 23

15) Flasher Connections

Verify the polarity of the flasher connections. Flashers must be connected according to **Installation** Steps 4 and 5. Examine the connectors for a ny hair-like filaments of wire between any of the contacts. Retest the system per the steps outlined in the previous section titled **Testing the IR System**

- **Good Operation:** Congratulations!
- **Poor Operation:** Go to Step 16

16) Flasher Output Too High

Some audio/video component's sensors are overloaded by too strong a command from the flasher. Connect the flasher(s) to the variable output of the IRP6+ and use

a 1/8" slotted screwdriver to reduce the output level to minimum (counter-clockwise). Retest the system per the steps outlined in the previous section titled **Testing the IR System**

- **Poor Operation:** Move the flasher so that it is farther away from the sensor window or off to the side of the sensor window. Retest the system.
- **Poor Operation:** Start raising the level (a quarter turn clockwise each time) and retesting until level is back to full.
- **Poor Operation Continues:** Go to Step 17

17) Test Flashers.

A) If you have only ONE FLASHER, reconnect it to the other flasher output. Retest the system according to the guidelines on page 11.

- **Good Operation:** Congratulations!
- **Poor Operation:** Go to Step 19

B) If you have MORE THAN ONE FLASHER, disconnect all of them and reconnect one flasher at a time. Test for improved operation. Continue testing until you have identified the defective flasher. Test all of your flashers.

- **All flashers appear defective:** Go to Step 18
- **One flasher doesn't work:** Return the defective flasher to your dealer
- **All flashers now work:** Congratulations!

18) Test Flasher Outputs

Reconnect one flasher to the second flasher output of the IRP6+. Test for improved operation. Repeat Step 16 (adjust flasher level and position). Test for improved operation.

- **Good Operation:** Congratulations!
- **Poor Operation:** Repeat this step with another flasher. Retest.
- **Poor Operation Continues:** Go to Step 19

19) Sensors in the Same Room as a Flasher?

- **If you have sensors in the same room as a flasher:** Go to Step 20
- **If all sensors are in remote loca-**

tions without flashers : Go to Step 21

- **If you have keypads only:** Go to Step 21

20) Optical Feedback Loop

If there is an IR sensor and an IR flasher located within the same room an "optical IR feedback loop" can occur. Replace the IRC-1 Flooding Flasher with an IRC-2 MicroFlasher on the front panel sensor window of each component. Place the enclosed IR blocking cover over each of the IRC-2 flashers. Retest the system.

- **Good Operation:** Congratulations!
- **Poor Operation:** Go to Step 16 (adjust Flasher Level and Position) Retest system.
- **Still Poor Operation:** Go to Step 21

21) Replace IRP6+ and Flasher(s)

Reconnect the system with a new IRP6+ and new flasher(s).

- **Poor Operation Continues:** Go to Step 22

22) Interference that Does Not Light the IR Test LED

Some very rare examples of interference (both optical and electromagnetic) do not light up the IR test LED but do prevent proper operation. Go to steps 36 and 37. Examine your installation carefully for a source of low-level optical or electromagnetic interference.

23) Disconnect All Sensors and Keypads and Test One Sensor Input

Disconnect all Sensors and Keypads. Reconnect one of the sensor cables and retest the system (Have someone watch the green IR LED on the IRP6+ while you aim a remote control at a remote sensor and press a button).

- **IR Test LED Flashes:** Go to Step 24
- **IR Test LED Off:** Go to Step 25

24) Test Second Sensor Input

A) If you DO NOT have a second sensor/ Keypad, Go to Step 25.

B) If you DO have another sensor/keypad, connect it to the second sensor input. Retest the system

Troubleshooting Guide continued

(Have someone watch the green IR LED on the IRP6+ while you aim a remote control at a remote sensor and press a button).

- **IR Test LED Flashes:** Go to Step 12
- **IR Test LED Off:** Go to Step 25

25) Bad Connections at the IRP6+ and/or at the Sensor/Keypad.

Verify that all connections are good both at the IRP6+ Sensor Inputs and at the remote sensor/keypad. Check that the jacket of each conductor has been properly stripped and inserted into the connector. Examine the connectors for a hair-like filament of wire between any of the contacts. Repair as necessary. Retest the system (Have someone watch the green IR LED on the IRP6+ while you aim a remote control at a remote sensor and press a button).

- **IR Test LED Flashes:** Congratulations!
- **IR Test LED Off:** Go to Step 26

26) Test Cable for Shorts

Disconnect the cable at both ends (at the sensor and at the IRP6+) and test it for shorts. Use an ohm meter or electrical continuity checker. You should read an open (Infinite Ohms) between Red and Bare, Red and Black or Bare and Black. If you find a short, replace or repair the cable as necessary. Retest the system (Have someone watch the green IR LED on the IRP6+ while you aim a remote control at a remote sensor and press a button).

- **IR Test LED Flashes:** Congratulations!
- **IR Test LED Off:** Go to Step 27

27) Test Cable for Opens

At one end of the cable, twist the exposed copper ends of the Red (+) and the bare (GND) conductors together. At the other end of the cable, use an Ohm meter or continuity checker to check for a break in the cable. You should read a short (zero ohms) between the exposed copper ends of the Red (+) and the bare (GND) conductors. Repeat this test with the Red (+) and the Black (DATA) conductors. If you find an open, replace or repair the cable as

necessary. Retest the system (have someone watch the green IR LED on the IRP6+ while you aim a remote control at a remote sensor and press a button).

- **IR Test LED Flashes:** Congratulations!
- **IR Test LED Off:** Go to Step 28

28) Connect Sensor to Other Input of the IRP6+

Disconnect the sensor and reconnect it to another sensor input on the IRP6+. Retest the system (Have someone watch the green IR LED on the IRP6+ while you aim a remote control at a remote sensor and press a button).

- **IR Test LED Flashes:** Congratulations!
- **IR Test LED Off:** Go to Step 29

29) Replace the IRP6+ and/or the Sensor/Keypad

If you have another IRP6+, sensor or keypad, change it and retest the system, otherwise return the IRP6+ and the sensor/keypads to your local Niles dealer for testing.

30) Disconnect All Sensors and Keypads

Observe the IR Test LED.

- **IR Test LED is ON or Flickering:** Go to Step 33
- **IR Test LED is OFF:** Go to Step 35

31) Move the IRP6+ to avoid Electromagnetic Interference

It is possible that the IRP6+ is receiving electromagnetic interference from a nearby television or other appliance. Move the IRP6+ to another location and reconnect the power supply. Observe the IR Test LED.

- **IR Test LED is ON or Flickering:** Go to Step 34
- **IR Test LED is OFF:** You have EMI in your original location. Relocate the IRP6+ according to the guidelines found in the **Installation Considerations** section.

32) Replace the IRP6+

If you have another IRP6+, exchange it and retest the system, otherwise, return the IRP6+ to your local Niles dealer for testing.

33) Test First Sensor Input

Connect one sensor/keypad to the first Sensor Input. Observe the IR Test LED.

- **IR Test LED Off:** Go to Step 36
- **IR Test LED is On or Flickering:** Go to Step 37

34) Test Remaining Sensor Inputs

A) If you DO NOT have a second sensor/keypad, Go to Step 12.
B) If you DO have another sensor/keypad, connect it to the second sensor input. Observe the IR Test LED.

- **IR Test LED is On or Flickering:** Go to Step 37
- **IR Test LED Off:** Go to Step 12

35) Test for Shorts

A) Verify that all connections at the IRP6+ are correct. Look for a hair-like filament of wire between the two contacts.

B) Verify that the sensor/keypad connections are correct. Look for a hair-like filament of wire between the two contacts.

C) Disconnect the sensor/keypad cable at both ends and test the cable itself for shorts. Use an ohm meter or electrical continuity checker. You should read an open (Infinite Ohms) between Red and Bare, Red and Black or Bare and Black. After testing all connections and cable, observe the IR test LED.

- **IR Test LED is On or Flickering:** Go to Step 38
- **IR Test LED is Off:** Congratulations

36) Test for Optical Interference

Reconnect the problematic sensor/keypad to the IRP6+. Cover up the Sensor with a piece of cardboard (your hand will actually create electromagnetic interference under some conditions). Observe the IR test LED.

- **IR Test LED On or Flickering:** Go to 37
- **IR Test LED Off:** Go to 36

37) Optical Interference

Identify the source of the interference. The most common sources of optical interference are listed in the order of their probability:

Troubleshooting Guide continued

A) Sunlight. Reflections from windows, mirrors, swimming pools, shiny floors or objects.

B) Fluorescent light fixtures.

C) Neon signs.

D) A malfunctioning IR Remote Control.

E) A malfunctioning Infrared Motion Detector on your Security system.

Either re-orient the sensor or move the source of interference. Niles infrared sensors have built-in filters to attenuate the effect of visible light. If you add additional filtration you will reduce the effectiveness of the system with remote controls as well as the interference.

If you are using the MS-1 or the MS-2 miniature sensors consider exchanging them for IRR-4D, TIR-1 or the CMS-3 ceiling sensor. These three sensors have AGC circuits which serve as automatic filters.

If you choose to attempt to filter an MS-1 or MS-2, try a temporary material (e.g. a single thickness of facial

tissue) and test whether filtration will solve the interference and still give acceptable range.

38) Electromagnetic Interference (EMI)

Identify the source of the interference. The most common sources of electromagnetic interference are listed in the order of their probability:

A) Televisions (particularly large direct view sets).

B) Wall-mounted light dimmers or variable speed controls for ceiling fans. These controls emit more interference when turned down halfway. They emit little or no interference when turned up all the way (brightest position).

C) Fluorescent lights (the electronic ballast sometimes emits EMI)

D) Large appliances (air-conditioners, pumps, motors, compressors etc.)

E) AC line noise (noise brought into the system via the wall outlet connected to the IRP6+) Identify the EMI source by turning potential sources

on and off (or fully up and fully down) and watching for any change in the IR Test LED on your IRP6+. Once you have identified the source of interference:

- 1) Move the sensor or the sensor cable away from the EMI source or move the source of the EMI away from the sensor or the cable.
- 2) Shield the sensor with a metal J-Box.
- 3) Connect the Sensor's GND terminal to true earth ground (if this isn't feasible use the IRP6+ GND terminal).
- 4) Place a ferrite ring around the cable creating the interference. Ferrite rings can be purchased from an electronic supply store.

Power Status—Introduction

By adding an IntelliPad™ to your IRP6+ Infrared Extender System you will add a remarkable level of convenience to your system. The IntelliPad is the world's first programmable, wall-mounted keypad system that provides a unique LED power status display and the convenience of true one-touch remote control of complex audio/video systems.

The IntelliPad's status feedback feature eliminates the guesswork common with standard IR control systems. The power LED on the IntelliPad indicates the On/Off condition of the system's preamp/receiver.

Built-in intelligence tracks the On/Off condition of the preamp/receiver so the IntelliPad knows when it's appropriate to issue the power command, even when the user doesn't. The system maintains perfect synchronization between the amplifier and the user.

By combining an optional Niles 12v DC power supply with your IRP6+

you can send a status signal to an IntelliPad without running any additional wiring. Built into the IRP6+ is a Niles Status Signal Generator. When the IRP6+ sees 12v DC at the status jack it broadcasts a Status signal over your existing IR sensor wires. Any IntelliPad connected to one of your sensor wires will display power status.

IMPORTANT: For the IntelliPad's status feedback feature to work, the pre-amp/receiver controlling your system should have a switched AC outlet, a switched outlet is a 120v AC outlet that switches off, when the preamp/receiver is off and switches on when it is on.

Figure 6 The IntelliPad

Source Select Keys

- A single press of one of these keys can:
1. Turn on the preamp/receiver if it was off.
 2. Change the input of your preamp/receiver to the selected source.
 3. Change the function of the Source Control Keys so that they operate the selected source.
 4. Display which source is selected by backlighting the corresponding **Source Label**.
 5. Turn on the local speakers

Status LED

When the preamp/receiver is on, the status LED is lit. The color of the LED displays whether the local speakers are on or muted.

- GREEN - Local Speakers and the Preamp/Receiver are on
- RED - Local speakers are off, but the system is on.
- OFF - System is off.

Source Control keys operate the selected source.

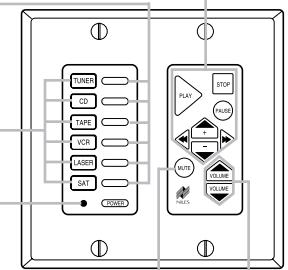

Mute Key — Controls the IntelliPad's built-in speaker mute feature. You can mute local speakers by pressing the Mute key. To turn the local speakers back on (or unmute), press either the Mute key or one of the six Source Select keys.

Volume Key — This key raises and lowers the volume of your main system amplifier.

Power Status—Installation Considerations

Proper Power Supply

You must connect a Niles 12v DC wall adapter (Niles XF00019) into the switched AC power outlet of the preamp/receiver in your system. Any 12v DC power supply with a minimum of 100mA current capacity can be substituted.

Extending the Cable

If you must extend the cable from the wall adapter to the IRP6+'s status input jack be sure to maintain correct polarity. The tip of the plug should be positive (+) and the sleeve negative (-). Any 16 gauge 2-conductor cable can be used to extend the power status cable up to 200 feet.

Checking the Power Supply

It is possible to check the status power supply itself and any connections that were made to extend the cable by inserting the status plug into the Power jack on the IRP6+. If the Power LED lights the status power supply and connections are OK. If the Power LED does not light check all connections and replace the power supply if necessary. For more details on incorporating the IntelliPad please refer to the IntelliPad's users manual.

CONVERTING A LOW VOLTAGE CONTROL OUTPUT TO 12V DC
Many components, particularly surround processors and digital preamplifiers, provide a low voltage whenever the component is "on" rather than in "standby." For the IRP6+ to correctly broadcast power status you must install an optional Niles OTI-512 Opto-Isolated trigger interface. The OTI-512 will convert 3-30 volts AC or DC to 12v DC.

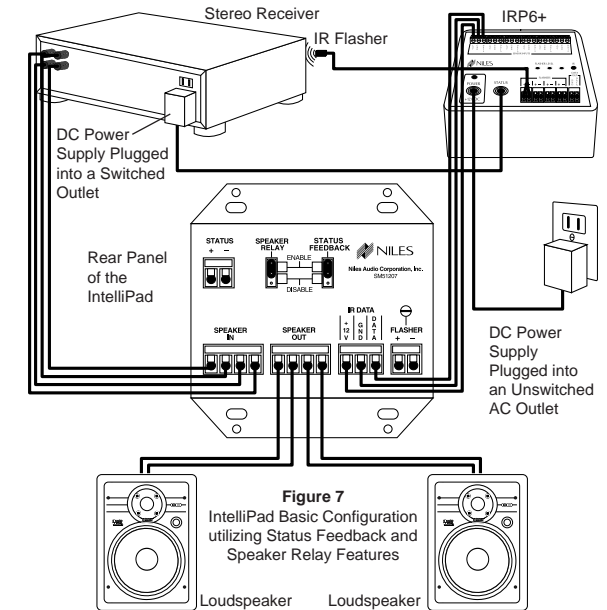

Specifications

IR System

Compatible with virtually all brands of remotes using carrier frequencies between 18 and 100kHz. As of this publication date, the only known components using carrier frequencies outside this range are Bang & Olufsen components and 1996 model year Pioneer receivers using the ISC remote control (e.g. VSX-D704S).

Wiring Requirements

Individual home-runs of 2 conductor shielded cable from each sensor/keypad, West Penn D291 or equivalent

Unit Dimensions

5" wide x 2" high x 4 1/8" deep

Power Requirements

12v DC 800 mA power supply (included).



www.nilesaudio.com

Niles Audio Corporation 12331 S.W. 130 Street Miami, Florida 33186 Tel: (305) 238-4373 Fax: (305) 238-0185

© 1999 Niles Audio Corporation. All rights reserved. Because Niles constantly strives to improve the quality of its products, Niles reserves the right to change product specifications without notice. Niles, the Niles logo, IntelliPad and Blending High Fidelity and Architecture are registered trademarks of Niles Audio Corporation. Decora is a registered trademark of Leviton Manufacturing Company. Printed in USA 11/95 DS00157A