

CM650SI

CEILING MOUNT

SPECIFICATIONS

DESIGN PRINCIPLE

Infinite baffle. Specifically designed for in-ceiling applications. Extended bass response, ultra-wide dispersion

WOOFER

6-1/2" dual voice coil polypropylene with a rubber surround

TWEETER

Dual 3/4" dome tweeters

RECOMMENDED AMPLIFIER POWER

5 to 125 watts per channel RMS

FREQUENCY RESPONSE

45 Hz to 20 kHz +/- 3 dB

SENSITIVITY

91 decibels for 2.83 volts of pink noise, measured at 1 meter on axis

IMPEDANCE

8 ohm nominal; 7 ohm minimum

OVERALL DIMENSIONS

9-1/4" diameter

MOUNTING DEPTH

3-3/8" (assumes 1/2" drywall)

CEILING CUT-OUT FOR RETROFIT

8" diameter

BEZEL FINISH

Pearl white ABS with non-glare finish

GRILLE COLOR AND MATERIAL

Pearl white, perforated aluminum

WEIGHT

7 lbs.

TOOLS REQUIRED

- Keyhole saw
- #2 Philips screwdriver or screwdriver bit
- Pencil



BLENDING HIGH FIDELITY AND ARCHITECTURE®

FEATURES & BENEFITS

The CM650SI stereo input ceiling mount loudspeaker offers Niles durability and installation ease and is designed for unobtrusive installations.

The CM650SI measures 9-1/4" in diameter. It features a weather-resistant dual input 6-1/2" polypropylene co-axial driver system with a rubber surround and powder coated aluminum grilles, making it suitable for bathroom and outdoor patio applications. It employs a bracketless

CONGRATULATIONS

Thank you for choosing a Niles Ceiling Mount loudspeaker. With proper installation and operation, you'll enjoy years of trouble-free use.

mounting system: simply cut a hole in the mounting surface and tighten the four clamps via front-baffle screws. The flush, MicroPerf™ grille can be painted or covered to blend with the surrounding decor.

PACKAGE CONTENTS

- 1 Piece Speaker With Grille
- 1 Piece Hole Template/Paint Mask

PLACEMENT CONSIDERATIONS

The CM650SI is designed to work well in any standard ceiling. The mounting surface must be at least 3/8" thick.

It will perform well in any air volume greater than .5 cubic feet.

WIRING CONSIDERATIONS

This speaker is designed to be minimally affected by long lengths of speaker wire.

The CM650SI will accommodate speaker wire between 12 and 22 gauge.

INSTALLATION PROCEDURE

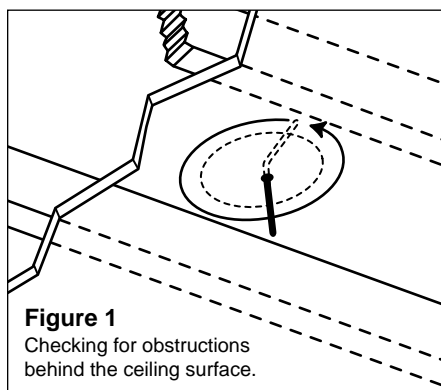

Figure 1
Checking for obstructions behind the ceiling surface.

1. Cut a foot-long piece of coat hanger. Bend the wire (creating a right angle) leaving 4-3/4" at one end for the CM650SI (this allows for the extra width of the mounting dogs). Poke the "L-shaped" wire into the pilot hole and turn it in a complete circle and move it into the ceiling cavity to make sure you have approximately 3-3/8" of depth. If the coat hanger movement is obstructed by anything, fill the hole(s) with spackle and try another location (See Figure 1).

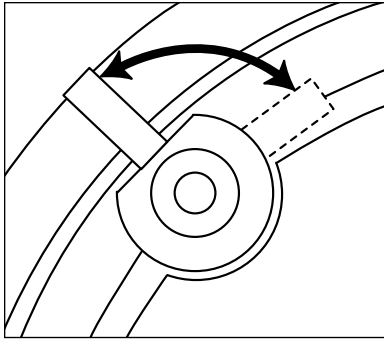

Figure 2
Detail of Mounting System

INSTALLATION PROCEDURE CONTINUED.

2. Locate the hole template and remove the inside portion of it. Save this part—it may be used as a paint mask. Use the inside of the template to trace the outlines at the desired location on the ceiling or wall. With a keyhole saw, cut along the penciled lines.

BE CAREFUL NOT TO CUT THROUGH ANY EXISTING WIRING.

3. Attach the speaker wires to the speaker. Be sure that proper phasing is observed.

4. There are four clamps which hold the speaker in place. The clamps are tightened via four front-baffle screws. To install the speaker, first rotate the clamps inward. Insert the speaker into the cutout and tighten the clamps by turning the

screws clockwise. **DO NOT OVER TIGHTEN THESE SCREWS.** Over-tightening the clamps may make the grille difficult to install (See Figure 2).

NOTE: The screws will be easier to turn if you “prime” them first. Before installing the speaker, turn the screws in and then turn them back out to their original positions.

5. Install the grille into the speaker. The grille fits tightly. This is to prevent the grille from becoming loose over time. Some effort and care is required when installing them.

REMOVING THE GRILLE

To remove the grille from the CM650SI, obtain a small paper clip (size #1, common) and bend the last quarter inch of it into an “L” shape. Holding the paper clip with a pair of pliers, insert the end

with the “L” into a hole near the edge of the grille. Remove the grille by pulling the paper clip towards you.

PAINTING THE SPEAKERS AND GRILLES

The CM650SI may be painted. The plastic will readily accept most any kind of paint.

The speaker must be masked prior to painting them. The inside portion of the hole template can be used as a paint mask. Remove the outside portion of the template by gently pulling along the perforation. Affix the mask to the front of the speaker using a piece of tape.

Fold the tape onto itself to form a double-sided loop. Affix the tape to the tweeter and place the mask onto the speaker.

The grille should be painted before it is installed. The best results will be obtained by using a spray gun or airless sprayer, thinning the paint (prevents clogging of grille holes) and by applying several light coats instead of one heavy one.



NILES®

NILES AUDIO CORPORATION
www.nilesaudio.com

NILES AUDIO CORPORATION

12331 S.W. 130 Street Miami, Florida 33186 Tel: (305) 238-4373 Fax: (305) 238-0185

©1999 Niles Audio Corporation. All rights reserved. Niles, the Niles logo, Blueprint Series In-Wall Loudspeakers, and Blending High Fidelity and Architecture are registered trademarks of Niles Audio Corporation. MicroPerf is a trademark of Niles Audio Corporation. All other trademarks are the property of their respective owners. Because we constantly strive to improve our products, Niles reserves the right to change product specifications without notice. The technical and other information contained herein is not intended to set forth all technical and other specifications of Niles products. Additional information can be obtained on-line at www.nilesaudio.com or by calling Niles at 1-800-289-4434. Printed in Taiwan 5/99 DS00253A