

**Niles Audio Corporation**

---

# **IntelliControl Reference Manual**

---

Version 8.1 April 2002



## Contents

<b>1A. IntelliControl Features and Benefits .....</b>	<b>1</b>
<i>A Complete System.....</i>	<i>1</i>
<i>One Touch “Intelligent Macros” To Turn The Entire Home Theater On or Off.....</i>	<i>2</i>
<i>Automatically Unmute the System.....</i>	<i>2</i>
<i>Manage and Automate “Unfriendly” Components .....</i>	<i>2</i>
<i>Trigger Screens, Screen Masking Devices, Projector Lifts, Curtains and Drapes .....</i>	<i>2</i>
<i>PC Programmable with IntelliFile II.....</i>	<i>2</i>
<i>Proudly Made in USA.....</i>	<i>3</i>
<b>1B. IntelliControl Parts Guide.....</b>	<b>3</b>
<i>The Tabletop Remote .....</i>	<i>3</i>
<i>The Main System Unit (MSU) .....</i>	<i>4</i>
<b>1C. Selling the System.....</b>	<b>6</b>
<i>Selling Automated Home Theater Systems .....</i>	<i>6</i>
<i>Solving The Problems of Conventional Home Theater Operation.....</i>	<i>6</i>
Problem One: Turning the System On .....	6
The IntelliControl Solution: Synchronization (Sync) .....	6
Problem Two: Selecting Inputs & Modes .....	8
The IntelliControl Solution: Software Managers to Select Inputs and Modes .....	8
<b>2A. Power Synchronization.....</b>	<b>11</b>
<i>Infrared Turn On/Off Requires “Sync” .....</i>	<i>11</i>
<i>Components that Don’t Need Sync – Those with Latching Power.....</i>	<i>11</i>
<i>Remember the Exception – Tuners built into Receivers and Televisions .....</i>	<i>12</i>
<b>2B. Sync Methods and Options .....</b>	<b>12</b>
<i>Video Sync .....</i>	<i>13</i>
Syncing the TV .....	13
<i>12 Volt Sync.....</i>	<i>13</i>
1. 12V DC Sync via a Wall Adapter Plugged into a Switched AC Outlet .....	13
2. Niles LS-1 Light Sensor .....	14
3. Niles OTI-512 Voltage Sensor.....	14
4. Niles APC-2 Current Sensing Switcher .....	14
5. Niles IPC-6 Current Sensing AC Power Controller .....	14
<i>Each Sync Connection on the Main System Unit Corresponds to a Particular Master Key on the Tabletop Remote .....</i>	<i>15</i>
<i>Conventional Labeling Rule: Video on the Left, Everything Else on the Right .....</i>	<i>16</i>
Once Again: Remember the Exception .....	16
<b>2C. Component Compatibility .....</b>	<b>16</b>

<i>Infrared Compatibility</i> .....	16
<i>Testing Components for Automation Conflicts</i> .....	17
<i>Testing Components for Sync Method</i> .....	18
Sync Off Delay .....	18
<b>3A. Pages, Keys, and Sequences</b> .....	<b>22</b>
<i>An Address For Every IR Command</i> .....	23
<i>Issue A Sequence From A Function Key</i> .....	23
<i>Purpose of the Master Key Pages</i> .....	24
<i>Purpose of the Default Page</i> .....	24
<i>Purpose of the Library Pages</i> .....	25
<b>3B. Master Key Automation: Part 1 - One Touch System Turn On</b> .....	<b>25</b>
<i>Sync Snapshot</i> .....	26
<i>Event One – Initial Sequence</i> .....	26
<i>Event Two - TV Power</i> .....	27
<i>Event Three - Preamp Power</i> .....	27
<i>Event Four - Component Power (Not Applicable to Master Keys Nine and Ten)</i> .....	27
<i>Event Five - TV Input</i> .....	27
<i>Event Six - Preamp Input</i> .....	27
<i>Event Seven - Surround Mode</i> .....	27
<i>Event Eight - Ending Sequence</i> .....	27
<b>3C. Master Keys: Part 2 - Special Features</b> .....	<b>28</b>
<i>Automation Bypass for Manually Adjusted Features</i> .....	28
Automation Bypass for a Typical Application.....	28
<i>How to Program “Component Power” for Multiple Master Keys which Share a Common Source</i> .....	29
<i>Press and Hold a Master Key</i> .....	30
<i>Custom Programming for Preamp/Receivers with Separate On/Off Commands</i> .....	31
<b>3D. Master Keys: Part 3 - Direct IR, Sequence IR, and Managers</b> .....	<b>31</b>
<i>Direct IR - A Different “Single” IR Code for each of the Component’s Inputs</i> .....	31
Testing Direct IR .....	31
<i>Sequence IR— a Single “Input Toggle” Command and a Secret Back-Door “Anchor” Command(s)</i> .....	31
Finding the Secret Back-Door “Anchor” Command.....	32
Testing the “Anchor” Command.....	32
<i>Input Manager – For Components with only a Single “Input Toggle” Command</i> .....	32
Testing the “Input Manager” Method.....	32
Determine the “Defaults” .....	32
<b>3E. Master Keys: Part 4 – Intelligent System Turn Off</b> .....	<b>33</b>

<i>Event 1 - "System Off" Initial Sequence</i> .....	33
<i>Event 2 - TV Auto Turn Off</i> .....	33
<i>Event 3 - Auto Volume Reset</i> .....	33
<i>Event 4 - Preamp Auto Turn Off</i> .....	33
<i>Event 5 - Component Auto Turn Off</i> .....	33
<i>Event 6 - "System Off" Ending Sequence</i> .....	33
<b>3F. The Audio, Video, and Assignable Relays with Control Voltage Output</b> .....	<b>34</b>
<i>Relay Voltage Limitations</i> .....	34
<i>Audio 12V Output</i> .....	34
<i>Video 12V Output and Relay</i> .....	34
<i>Assignable 12V Output and Relay</i> .....	34
<b>3G. Utilities</b> .....	<b>35</b>
<i>ID Code</i> .....	35
<i>Volume Reset</i> .....	35
<i>IR Routing</i> .....	35
<i>Dual TV</i> .....	36
<i>Mute Manager</i> .....	36
<b>4A. Using Your Original Remote Controls via an IR Repeater System</b> .....	<b>37</b>
<i>Integrating a Second Zone</i> .....	37
<i>Turning On Common Sources in Multi-Zone Systems</i> .....	38
<i>Integrating the Niles RVL-6 and MRZ-6 Multi-Room Controllers</i> .....	39
<i>Multiple TV Array In A Media Room</i> .....	39
<i>Integrating the Niles IntelliPad™ Into the Home Theater</i> .....	39
<i>Integrating a Learning Touchscreen Into An IntelliControl Home Theater</i> .....	39
<i>Teach the RF/IR Conversion Codes for the Master Keys, Function Keys, and System Off Key</i> .....	40
<b>Step-by-Step Installation of a New System</b> .....	<b>41</b>
1. <i>Connect, Power Up, and Test The Home Theater</i> .....	41
2. <i>Check MSU Location for Freedom from Interference</i> .....	41
3. <i>Connect and Power Up the MSU, Your PC, and the IntelliFile II</i> .....	41
5. <i>Testing and Troubleshooting RF Transmission and Reception</i> .....	42
6. <i>Connect Flashers and Sync Cables</i> .....	43
7. <i>Flasher Level Check</i> .....	44
8. <i>The IR/RF Test LED</i> .....	45
<b>Specifications</b> .....	<b>46</b>

<i>The IntelliControl Tabletop Remote</i> .....	46
<i>The IntelliControl Main System Unit</i> .....	46

---

# IntelliControl® Home Theater Automation System

## 1A. IntelliControl Features and Benefits

Introducing the IntelliControl, the world's first affordable home theater automation system expressly designed to provide true one-touch operation. Unlike universal remote controls, the IntelliControl System senses the actual on/off state of all of your audio/video components. When you press a Master Key, the built-in microprocessor has the intelligence to decide which components need to be powered up, depending on what Master Key was selected and the On/Off state of the components.

After the system components have been turned on, the IntelliControl issues all of the necessary surround-sound mode commands, the preamp input selection commands, the TV input commands, and any "play" or "favorite station" commands. For the first time, most anyone in the family can operate the system without training, prompting or head-scratching.

Ten Master Keys can be custom labeled to reflect your system components or features. When you select a source, it lights up letting you know it's ready to be controlled. Traditional universal remotes are confusing because "aux" might actually select the satellite receiver, and "VCR2" selects the TV. Now, each of the sources in your system are correctly labeled. By pressing one of these Master "scene-setting" Keys, your system is completely turned on, configured, and set up to watch and control the selected source.

The only other systems capable of this unique combination of custom labeling and full automation of a mixture of multi-brand components are very expensive touchscreen automation systems. In addition to the expense, touchscreens are menu-driven, and always require more than one step to operate. The IntelliControl offers genuine one-touch operation at an affordable price.

### A Complete System

The system consists of an ergonomically designed RF (radio frequency) Tabletop Remote Control and an "intelligent" Main System Unit (MSU). Powerful combinations of hardware and software functions within the Main System Unit manage and control every aspect of the home theater.

## **One Touch “Intelligent Macros” To Turn The Entire Home Theater On or Off**

Normal home theater system operation requires you to turn on multiple components. It is easy to make a mistake, which can create a situation where you must be a detective and hunt down the fugitive component that is “off”, when it really should be “on”. The IntelliControl eliminates all of this troubleshooting. A single touch of any of the ten installer labeled “scene-setting” keys (typically labeled for sources e.g. TV, VCR, CD) will initiate an intelligent sequence of commands (macro).

The IntelliControl will only issue a component’s power command if it is off. All of the necessary components are turned on, every time. After the system components have been turned on, the IntelliControl automatically completes the system configuration, enabling you to watch and listen to the selected source. Now, a complex mix of different brands of audio/video components can be operated with the same ease and simplicity of a traditional television set.

## **Automatically Unmute the System**

Many surround-sound preamps or receivers can unpleasantly surprise you with their “mute” functions. For example, if you mute the system to answer a phone call and then press a Master Key or the “Volume Up” Key, the volume will be too low. If you first raise the volume then remember that you muted it, a press of the “Mute” button will issue a deafening blast.

The IntelliControl is capable of “managing” the mute command. The system will mute when you press the “Mute” key. However, it will now unmute automatically whenever you press a Master Key, “Volume Up” or the “Mute” key.

## **Manage and Automate “Unfriendly” Components**

Many high-performance audio/video components have remote control functions that are impossible to automate with conventional automation equipment. The components are really just designed for the user who demands manual control at all times. The IntelliControl has unique software “managers” which enable complete automation of components that are difficult to automate. For the first time, components chosen for optimum performance can be automated using the IntelliControl.

## **Trigger Screens, Screen Masking Devices, Projector Lifts, Curtains and Drapes**

The IntelliControl provides dedicated 12-volt DC triggers for both the Video and the Audio Scenes. The Video scene also triggers a latching (normally open) and a latching (normally closed) contact relay. An "assignable" relay and 12v DC voltage can be triggered by any key as a step in a programmed sequence. These relays and voltages enable devices which are not IR controlled to be automated by the IntelliControl system.

## **PC Programmable with IntelliFile II**

An IntelliControl system configuration can be programmed, saved, and edited using the Niles IntelliFile II Programming Software and interface. A PC running Windows 95 or higher is required. Niles does not offer a Mac compatible version at this time.

## Proudly Made in USA

The IntelliControl is designed and built in the USA and comes with a limited two year parts and labor warranty.

### 1B. IntelliControl Parts Guide

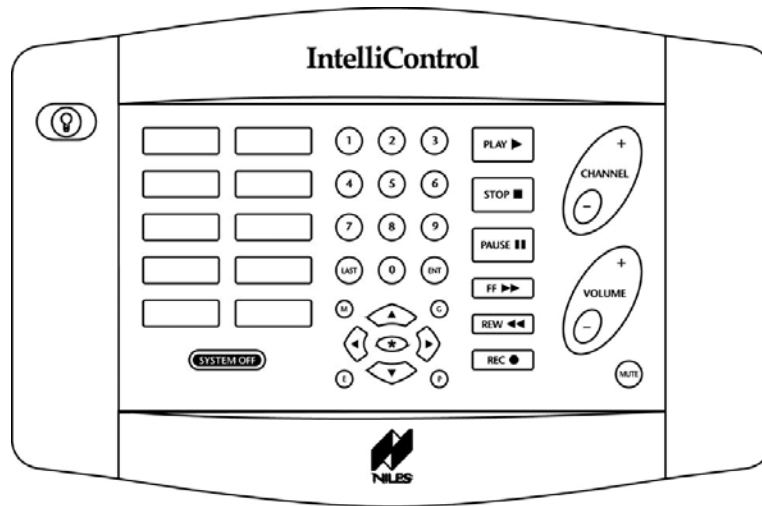

Figure 1 The IntelliControl Tabletop Remote

### The Tabletop Remote

The Tabletop Remote is a radio frequency (RF) transmitter which communicates with the Main System Unit (MSU) on a RF carrier frequency of 418MHz. The Tabletop Remote features the following:

- **Ten Master Keys** – The ten Master Keys on the left side of the remote may be custom labeled and will initiate the IntelliControl's automation functions when programmed via the IntelliFile II PC Interface and Programming Software. Pressing a Master Key will prompt the MSU to check the On/Off status of all of the components in the system and issue the necessary IR commands to configure the system so the user may enjoy the selected source.
- **System Off Key** – When pressed, the Tabletop Remote will instruct the MSU to check the On/Off status of all the components in the system and issue the necessary IR commands to power down the system.
- **Backlight Key** – Pressing the Backlight Key (located on the upper left corner of the Tabletop Remote) will illuminate all the keys to enable complete control of the system in dark rooms.
- **Function Keys** – The thirty-two Function Keys include the numeric, menu, transport, mute, volume, and channel keys. Once a Master Key is selected, the Function Keys

correspond to the functions of that selected source. However, the volume and mute keys are usually programmed to control the preamp only.

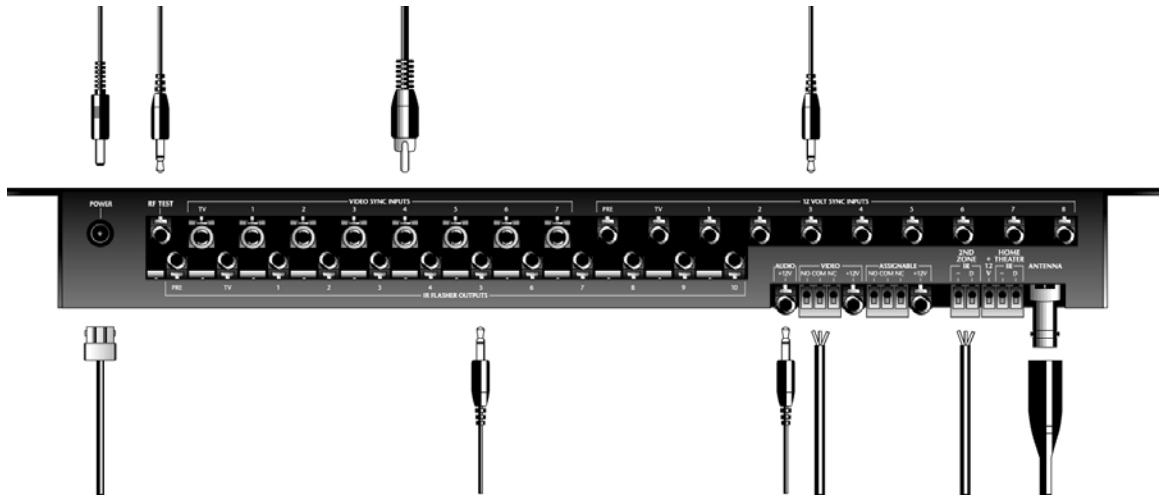

Figure 2 Main System Unit – Top View

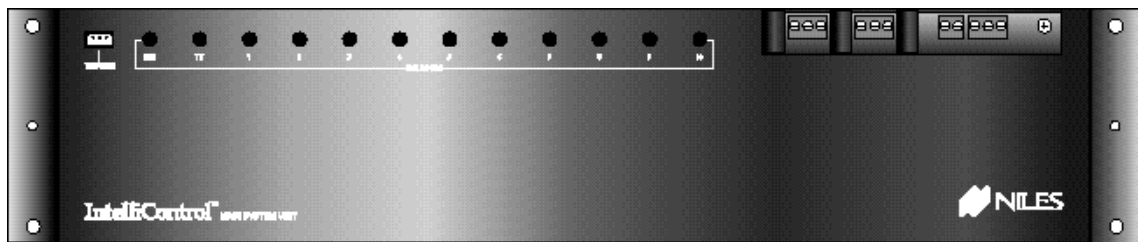

Figure 3 Main System Unit – Front View

## The Main System Unit (MSU)

The Main System Unit is the “brain” of the IntelliControl system. Once a RF command is issued from the Tabletop Remote, the MSU processes the command and controls all functions of the system. All programming is stored inside the MSU. The Main System Unit features the following:

- **Power Connector** – Located on the upper left side of the MSU, the Power Connector accommodates a 12V DC 1A UL approved external power supply (XF00044 - included).
- **RF Test Port** – Also located on the upper left side of the MSU is the RF Test Port. The RF Test Port enables you to receive real-time confirmation that RF signals are received and understood, detect interference, and test for sync status. The bicolor

RF/IR Test LED (FG00727) is available as an accessory, and should be sold and installed in every IntelliControl home theater.

- **Video Sync Inputs** – The eight Composite (RCA) Video Sync Ports are provided to sense the on/off power status of IR controlled components with video output. Your system design may require additional video cables and “Y” adapters.
- **12V Sync Inputs** – The 12V Sync Inputs are provided to sense the on/off power status of IR controlled components. Your system design may require 12V DC wall adapters or Niles switchers (APC-2, LS-1, OTI-512) with a 10’ Accessory Cable (FG00724).
- **Transfer Connector** – The three conductor Transfer Connector enables the transfer of programming information from the IntelliFile II PC Interface or the original IntelliControl Programmer to the MSU and vice versa. You may want to permanently install a 20’ Transfer Cable (FG00725) to provide future access for programming updates.
- **IR Flasher Outputs**- The twelve IR Flasher Outputs issue IR codes to IR controlled components. Your system design may require IRC-2P MiniFlashers (FG00726) and/or 3.5 to 3.5 mono mini-plug cables for hardwired connections to compatible components.
- **12V DC Control Voltage Outputs** – These connections can be used to trigger screens, Niles switchers, and other devices. Your system design may require 10’ Accessory Cables (FG00724). The IntelliControl features an “Audio 12V” output (active whenever a source that utilizes the preamp is selected), a “Video 12V” output (active whenever a source that utilizes the TV is selected), and an “Assignable 12V” output (activated as part of a sequence with the “Assignable Relay On” command).
- **Dry Contact Closures / Relays** – These connections can be used to trigger lights, curtains, screens, lifts, and other devices. Your system design may require multi-conductor cable. The IntelliControl features a “Video Relay” (active whenever a source that utilizes the TV is selected), and an “Assignable Relay” (activated as part of a sequence with the “Assignable Relay On” command).
- **IR Data Input Connectors (“Home Theater IR” and “Second Zone IR”)** – These connections enable IR data to be fed into the MSU from Niles IR sensors, keypads, IR Main System Units, or Multi-room Controllers around the house. IR data received at the “Home Theater IR” port is passed through all flashers. IR data received at the “Second Zone IR” port is passed through flashers 1 – 8 only.
- **Antenna Socket** – The BNC connector accommodates the supplied antenna. The antenna must be installed perpendicular to the ground for best results. A 6 meter antenna extension cable and mounting bracket are included if remote installation of the antenna is necessary.
- **IR Flasher Level Controls** – The twelve flasher level controls enable the installer to control the strength of the IR output sent to each of the components in the system. Flasher strength increases as the pots are turned clockwise (a jeweler’s screwdriver is required). Before beginning to program the system, it is recommended that a Niles IR Sensor be connected to the MSU’s “Home Theater IR” port and each of the flasher level adjustments be set using the components’ original remote controls.

## **1C. Selling the System**

### **Selling Automated Home Theater Systems**

In the past, selling a home theater system has always involved system design trade-offs. With every profitable upgrade you sell to your customer there is a “hidden” cost to you after the installation, which is your time.

Along with selling and installing the system, you must assume the responsibility for training the customer to actually use the new features or enjoy the enhanced performance. The frustration many consumers feel, even after repeated training sessions, certainly limits referrals and sometimes leads to refunds. In any event, the time required to drill customers so that they can reliably turn on and operate the system can be ridiculously expensive for you and tedious for your customer. The IntelliControl enables you, the salesperson, to design and sell absolutely automated home theater systems (systems that require minimal training to operate and which generate repeated referrals).

In order to successfully sell the IntelliControl to consumers, you should be able to effectively present what “Home Theater Automation” means, in terms the consumer will understand. The following sections elaborate how the IntelliControl’s automation differs from anything that has ever been sold and installed into a home theater at this price point.

### **Solving The Problems of Conventional Home Theater Operation**

The IntelliControl uses a unique approach to solve the classic problems of operating a home theater. In this section, we will take a closer look at what those problems are, and how the IntelliControl solves them.

#### **Problem One: Turning the System On**

In a conventional system, turning on a home theater with a remote control can be so difficult, that most people simply walk up to the equipment where they can see each component and try to remember what needs to be done. Since most components feature “toggle” power commands (one button which turns the component both “On” and “Off”), you cannot simply press the power button on each of your remotes in turn or issue a macro of many power commands from a sequencing remote or touchscreen. For example: If you put the videotape into your VCR, it would automatically turn on, and the act of pressing the power button on each of your remotes (or pressing the macro button on your touchscreen) would turn on the rest of your system, but would turn off the VCR).

#### **The IntelliControl Solution: Synchronization (Sync)**

The IntelliControl’s Main System Unit is connected to all of the home theater components. Its unique video and 12V sensing circuits enable it to actually “know” whether each component is on or off.

When the user presses any Master Key, the IntelliControl’s microprocessor checks the power status of each component and synchronizes the system to the end user’s desires by issuing only the necessary power commands. No matter what their previous on or off states, the IntelliControl will know exactly which components need to be powered up.

Power synchronization is not just used when the system is first turned on. It is also used when a new Master Key is selected. The IntelliControl checks to see if anything needs to be turned on or off, and issues the necessary power commands.

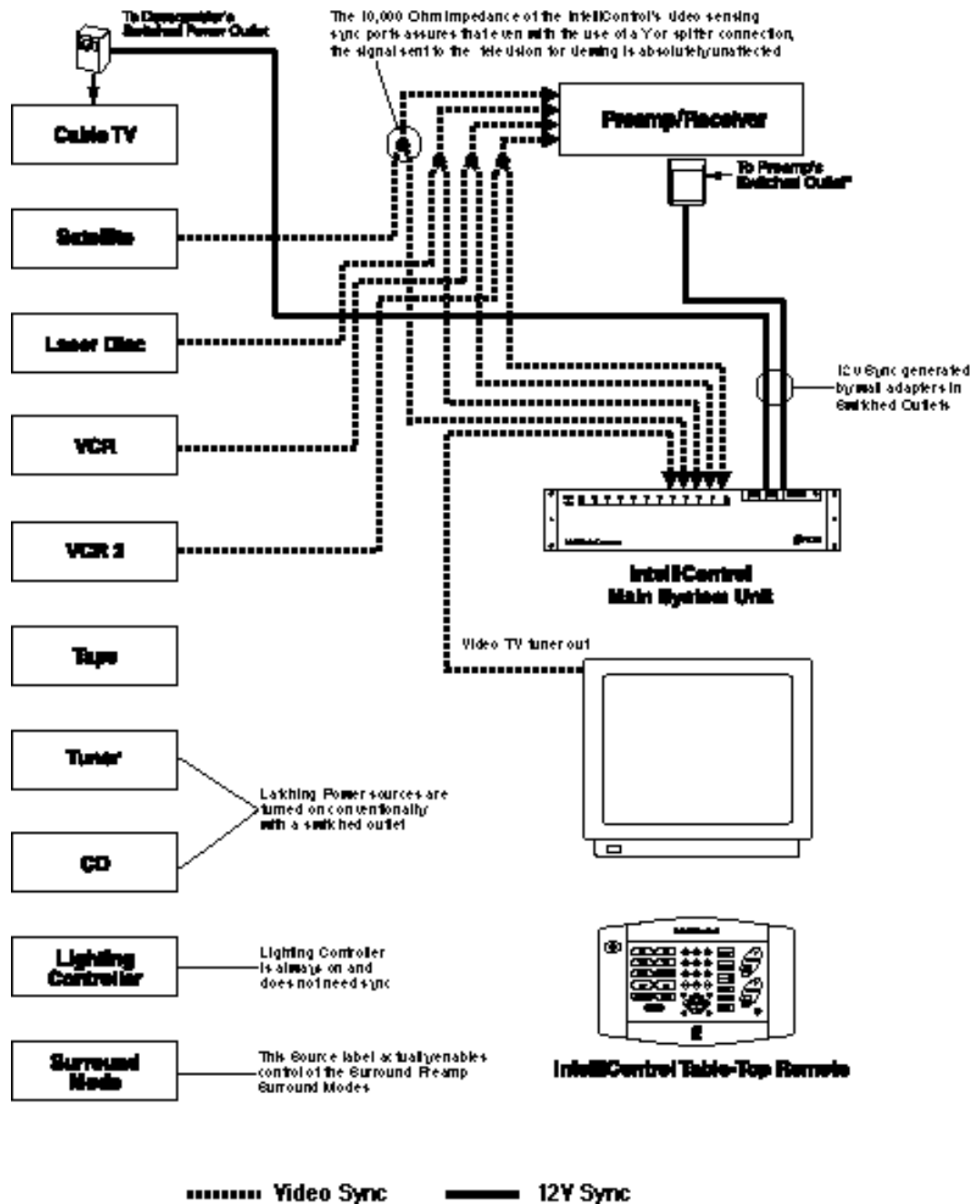

Figure 4 System Schematic

## **Problem Two: Selecting Inputs & Modes**

Home theaters need to have the surround receiver's audio inputs selected, the correct surround-sound mode selected, and the correct TV input selected. Even if there is a separate button for every mode or input, the user must remember which input label is correct for each component and keep track of which remote is which. Although some remotes have the ability to issue "macros", most systems incorporate at least one component that is "macro-proof" (a component that uses a single "INPUT" or "MODE" command to cycle through all of the choices). There is no way for the remote control to "know" which input was last selected. So, the consumer must remember which input it was and cycle through the choices manually. Operation is frustratingly complex for anyone.

### **The IntelliControl Solution: Software Managers to Select Inputs and Modes**

The IntelliControl's Main System Unit is programmed with powerful software "managers" that automate Input and Mode selection. No matter what type of IR command is required to change the inputs or the modes, The IntelliControl automatically selects the correct configuration for the source selected.

Additionally, for the first time, you can design sophisticated configurations that improve system performance without worrying about the difficulty the end-user might have remembering everything (i.e. you could run S-Video direct to the TV's S-Video input for the DSS, while composite video is run from the other sources to the TV's video input).

This automation does not get in the way of hobbyists who like to play with the surround-sound modes. The IntelliControl will automatically select the normal surround-sound mode for each input when the user presses a Master Key.

However, if the hobbyist decides to experiment with different modes, he/she can press one of the ten custom labeled Master Keys (labeled "Surround" for example), change and adjust the surround-sound, and when they return to the last source selected, the surround-sound mode will not automatically change back to the normal mode (this is an example of the IntelliControl's "Automation Bypass" feature). Only when the user selects a new source will the IntelliControl take over again and automatically select the default surround-sound mode for the new source. Now, the hobbyist can peacefully coexist with the rest of the family, because he/she will never accidentally leave the system in the wrong input or the wrong surround-sound mode.

## **Problem Three: Decorating Electronically – Putting All The Components In Plain Sight**

If the equipment is placed out of sight behind cabinet doors and an infrared repeater system is installed, the user cannot see which component is on, which input is selected, etc. Either way, the user is cursed with either a stack of components with cryptically

flickering LEDs in plain sight or a cabinet full of components that can only be operated if the doors are open.

### **The IntelliControl Solution: Automation Allows Behind Closed Door Operation**

Because the IntelliControl automates all of the system's functions, the user doesn't need to check the power status or the currently selected input of each component. The IntelliControl is constantly checking the power status and the software Managers are correctly configuring the system for any source. As a result, the components can be placed behind closed doors.

### **Problem Four: When The System Turns On, The Volume Is Too Low, or Too High**

Surround-sound preamps/receivers typically stay at the last volume selected when they are turned off. As a result, turning on a system can sometimes be puzzling because there is no sound, while at other times, turning on a system can be ear-shattering.

### **IntelliControl Solution: The Volume Resets Automatically At Turn Off**

The IntelliControl can be programmed to automatically reset the receiver's volume to a comfortable level. When the "System Off" key is pressed, the IntelliControl can be programmed to issue the "Volume Down" for as long as necessary to take the preamp/receiver to minimum, then raise it to a comfortable level regardless of how loud or soft the system had been playing. Only then does the IntelliControl turn the system off. The system always turns on at a moderate volume setting. No more puzzling or surprising accidents.

### **Problem Five: The Pitfalls of Mute**

It has been traditional for most surround-sound receivers and preamps to offer the end user a separate "Mute" button. This button has created thousands of service calls worldwide. You press "Mute" once, the system mutes, you press it again and it unmutes. However, the user must remember that the system is muted. If the user forgets, then there is no sound. Or worse, a service call is created.

### **IntelliControl Solution: Software Managers to Manage Mute**

The IntelliControl's Main System Unit can be programmed to automate the "Mute" command. Now, when one person presses "Mute", nobody has to remember anything. The IntelliControl remembers. When anyone touches any key, the preamp will unmute.

### **Problem Six: Infrared Remote Controls Are Line-Of-Sight Only**

In a conventional system using a "macro" remote, various problems can occur if the remote control is not pointed correctly, or not held steadily in one position until all of its commands are issued. If the user's hand slips, or someone walks by, some of the commands may not be received. Annoying problems, which are exaggerated in larger rooms, will occur.

### **IntelliControl Solution: Radio Frequency Commands Between the Tabletop Remote Control and the System**

The IntelliControl issues a single RF "automation" command when a button is pushed. Because radio signals operate at any angle and cannot be physically blocked, the system's automation is extremely reliable. All macros are issued by the MSU, which feeds IR commands directly to the components. The IntelliControl provides the end-user with one-touch operation every time.

---

# Power Synchronization and Component Compatibility

## 2A. Power Synchronization

### Infrared Turn On/Off Requires “Sync”

Every component which requires an infrared command to turn “On” or “Off” must be synced to the IntelliControl. Based on the “sync status” of the selected component, the IntelliControl will know whether or not to issue a “Power” or “On” command when a Master Key is selected. The same basic procedure applies to turning the system off. The IntelliControl monitors the on/off status of the components in either of two ways, “12V Sync” and “Video Sync”.

### Components that Don’t Need Sync – Those with Latching Power

Components which “latch” into an “On” state when power is supplied do not need sync. The term “Latching Power” describes any component which has a Power button which “latches” into the “On” position and can be turned on automatically when AC power is supplied. “Single” and “5-disc” CD players, as well as most Tape Decks traditionally plug into the switched outlet of the preamp/receiver and do not require IR “power” or “On” and “Off” commands to manage their power. Check the power consumption of each device in the system and total them. If all of the connected component’s combined power consumption exceeds the limitations of the preamp’s switched outlet, you must specify a Niles AC-3 to switch the “On” and “Off”. See *Figure 9*

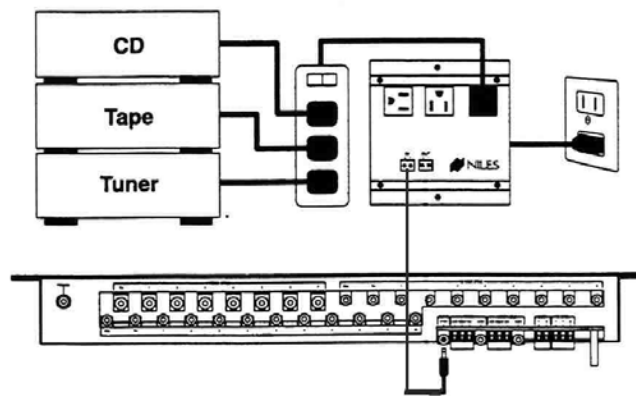

**Figure 6** Using the Niles AC-3 to switch on source components featuring “latching” power via the Audio Control Voltage Output. (The Audio 12V is automatically activated whenever a source that utilizes the preamp is selected).

For some components, it may be useful to turn them on and off with a Niles AC-3 triggered by one of the three relay voltages (“Audio”, Video”, or “Assignable”). You could elect to turn on and off a latching power CD player via the Assignable Relay if you specified an AC-3 to power it on and off. When programming, you could add the “Relay On” command to the CD Master Key’s Ending Sequence and the “Relay Off” command to all other Master Keys and the “System Off” Key.

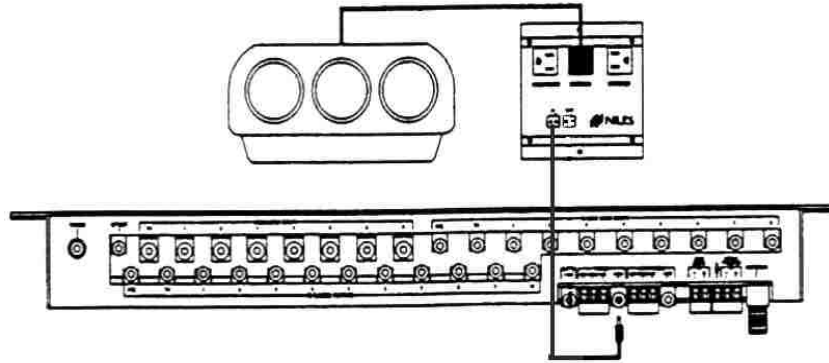

**Figure 7** A projector with latching power may be turned on via an AC-3 triggered by the Video Control Voltage Output. (The Video 12V Output is automatically activated whenever a source that utilizes the TV is selected).

### **Remember the Exception – Tuners built into Receivers and Televisions**

It is important to note that a stereo receiver has both a tuner and a preamp in one chassis. If the receiver does not feature separate “On” and “Off” commands (or latching power, in which case it could be activated via the “Audio 12V” trigger and an AC-3 as described above), it must be synced to the “Preamp 12V” sync port.

Since the receiver’s AM/FM tuner is automatically turned on/off with the receiver, the tuner itself does not need sync (or to have a “Component Power” command programmed on the tuner’s page under “Components” when programming with IntelliFile II). Essentially, the tuner is treated as a component with latching power. Likewise, most televisions have both a television tuner and a television monitor in one chassis. You sync the television monitor to the TV’s dedicated sync port, and treat the television tuner as a source with latching power.

## **2B. Sync Methods and Options**

The following are the methods you will use to signal the IntelliControl that a component is on or off.

## Video Sync

Most video sources provide either a picture or a blue-screen when the device is on. Using a Y-splitter, this video output can be routed to both the video switching Preamp (or TV) and to the MSU's composite video sync port that corresponds to that source's Master Key.

*Note: The labeling of the Master Keys on the Tabletop Remote must match the sync connections on the MSU. (For example, if the VCR is Master Key #4, one side of the VCR's split video output must be connected to video sync port #4).*

The IntelliControl video sync ports have an input impedance of 10,000 ohms. This high impedance circuit assures that even with the use of a "Y" or splitter connection, the signal sent to the television (or Preamp) is absolutely unaffected. Typically, a "Y" connector and an additional video cable are needed for video sync. If the component has more than one video output, only a cable is needed.

### Syncing the TV

Televisions, which have multiple inputs, present a sync problem. Some TV's do not output a video signal from the Monitor Video output when there is no signal coming into the selected input. Thus, the IntelliControl will be deceived into thinking that the TV is off, when it is on. Although a TV's monitor output will not provide reliable sync, there are four options:

1. Use the TV's "Tuner Output" if available. This will ensure that the Sync is reliable.
2. Specify a Niles APC-2 current sensing device to detect the flow of current to the TV when it is on. *Note: This is the only reliable way to sync a Plasma TV (assuming it does not feature separate "On" and "Off" codes).*
3. Use a Niles LS-1 Light Sensor. (See "12V Sync" options below)
4. Use a TV with separate "On" and "Off" commands.

*Note: The TV's sync signal output (video or 12V) must be connected to the dedicated "TV Sync" port on the IntelliControl MSU.*

## 12 Volt Sync

The IntelliControl Main System Unit has 12V Sync connections for the system's preamp/receiver, TV Monitor (or projector), and up to eight source components. The 12V Sync signal lets the IntelliControl know whether the component is on or off and can be supplied by five different methods:

### 1. 12V DC Sync via a Wall Adapter Plugged into a Switched AC Outlet

Many preamps, integrated amps, receivers, surround-sound processors, and cable TV descramblers have a switched AC outlet (i.e. the outlet is hot when the preamp is "on", and dead when the preamp is "off") to automatically power up components with latching power. In an IntelliControl system, the switched outlet may be expanded with an extension cord or power strip to accommodate a 12V DC 200mA wall adapter and any "latching power" components you may be using. The output of the wall adapter is connected to the IntelliControl's dedicated "Preamp 12V" sync input.

## **2. Niles LS-1 Light Sensor**

The Niles LS-1 Light Sensor was designed to detect a change in brightness on a component's front panel display. When it senses a change in brightness, the LS-1 outputs a constant 12V DC 500mA control voltage. A blocking cover is provided to prevent ambient light from falsely triggering the LS-1.

*Note: You may choose to sync direct-view or rear-projection televisions with the LS-1 Light Sensor. In this sync application, the LS-1's sensor is attached to the rear of the TV using the blocking cover (or better yet – to the flyback transformer inside the TV. The flyback transformer resembles a automobile alternator and is located near the TV's main power supply and AC power cord connection). The LS-1's sensitivity is adjusted to output a 12v DC sync signal only when the TV is on.*

*Additionally, when syncing multi-disc CD changers or other digital components, it may be possible to install the LS-1's sensor inside the component's optical digital output jack to detect the presence of light coming from that port when the unit is powered on. The unit must not emit any light from this port when the unit is in standby!*

## **3. Niles OTI-512 Voltage Sensor**

The Niles OTI-512 Voltage Sensor senses any control voltage between 3 and 30 volts AC or DC, and outputs a 12V DC 500mA control voltage. The 12V DC output is connected to the IntelliControl's sync input dedicated to that component.

An accessory cable (the Niles FOS-512) will connect a Fosgate, Lexicon, Citation, or Synthesis preamp to the OTI-512.

## **4. Niles APC-2 Current Sensing Switcher**

The Niles APC-2 Current Sensing Switcher senses any change in power consumption that is greater than 30 watts. When it senses that the power consumption has increased (by the component turning on), it outputs a 12V DC 300 mA control voltage. In an IntelliControl system, the component's AC power plug is plugged into the unswitched "Sensing" socket on the APC-2. The 12V DC output is connected to the IntelliControl's sync input dedicated to that component.

The APC-2 has several other features. For more info, please look up the APC-2 on our website: [www.nilesaudio.com](http://www.nilesaudio.com)

## **5. Niles IPC-6 Current Sensing AC Power Controller**

The Niles IPC-6 Current Sensing Switch senses any change in a component's power consumption that is greater than 3 watts. When it senses that the power consumption has increased, it outputs a 12V DC 300mA control voltage. In an IntelliControl system, the component's AC power plug is connected to the unswitched "Trigger" socket on the IPC-6. The 12V DC output is connected to the IntelliControl's sync input dedicated to that component.

The IPC-6 is not a surge suppression device, but it does have several other useful features. For more info, please look up the IPC-6 on our website: [www.nilesaudio.com](http://www.nilesaudio.com)

## Each Sync Connection on the Main System Unit Corresponds to a Particular Master Key on the Tabletop Remote

The labels typically represent the sources of a system. Master Keys 1 through 7 feature both “12V” and “Video” sync capabilities, Master Key 8 features only “12V” sync, but Master Keys 9 and 10 have no sync connections at all. For each component, you must utilize a Master Key, which has the necessary sync capabilities. The preamp/receiver and the television monitor do not need a Master Key assigned to them (but you may choose to assign Master Keys to the receiver’s AM/FM tuner and the TV’s internal tuner). The TV monitor and Preamp are system components that are needed to listen to and watch a component. Therefore, they have been permanently assigned their own sync connections.

PRE - The surround-sound preamp/receiver for the system is assigned the “PRE 12V” sync connector.

TV - The Television Monitor for the system is assigned to either the “TV 12V” or the “TV” Video Sync connector. *Note: The “TV” Video Sync connection method is reliable only if the TV you are using has a “Tuner” output. Using the TV’s “Monitor” or “Video” output is not reliable.*

MASTER KEYS ONE through SEVEN - These Master Keys are assigned both “12V” and “Video” sync connections.

LABEL EIGHT - This Master Key is assigned a “12V” sync connection only.

LABEL NINE and TEN - These Master Keys do not feature any sync connections at all. However, these keys may be used as Master Keys if their components have “latching power” or separate “On” and “Off” commands.

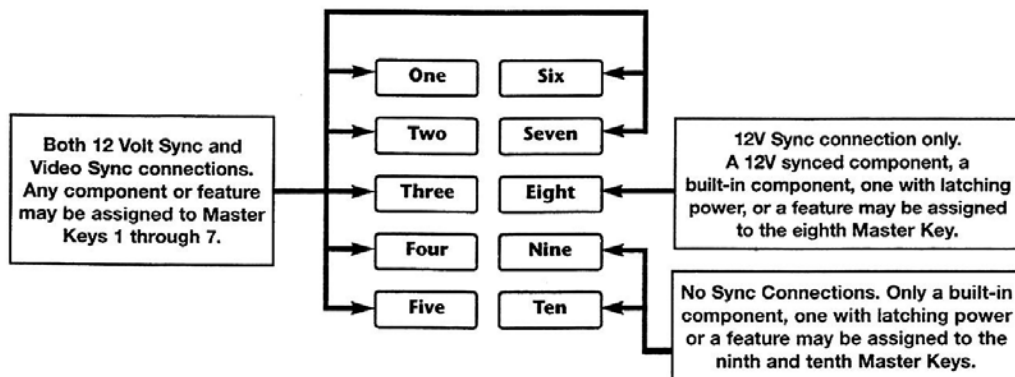

Figure 8 Master Key Sync Features

## **Tabletop Labeling Rule: Video on the Left, Everything Else on the Right**

Since most video components require sync, it is conventional to use the left hand column of the tabletop remote for video sources, and utilize the right hand column for the rest of the system. Typically, audio sources, sources with built-in or latching power, components which are always on (i.e., lighting controllers), and manually controlled features are usually configured to master Keys on the right side of the Tabletop Remote.

### **Once Again: Remember the Exception**

Since the IntelliControl will be programmed to turn on the TV Monitor whenever a video Master Key is pressed, there are special sets of sync connectors dedicated to the TV and are unrelated to any of the other Master Keys. Likewise, the Preamp/Receiver has its own Preamp sync and flasher connections unrelated to any of the other Master Keys.

If the television's built-in tuner is a source for the system or if the receiver's built-in AM/FM tuner is a source, Master Keys do need to be assigned. However, even though the TV and the Preamp need sync, the Master Keys for their internal tuners do not need sync (because they represent the components which are built into the TV and the Preamp). The IntelliControl will automatically check the sync of the Preamp when the "AM/FM" Master Key is pressed, so it is not necessary to check the sync for the receiver's tuner as well.

Because of this, you may assign the labels "TV" and "AM/FM" to any of the ten Master Keys (including Master Keys 9 and 10), since sync for those sources is not necessary.

## **2C. Component Compatibility**

### **Infrared Compatibility**

All audio/video components in the system must be remote-controlled by infrared (IR). The system was designed to be compatible with virtually any brand of equipment that transmits IR commands on carrier frequencies between 26kHz and 110kHz, as well as 455kHz (i.e. the IntelliControl is compatible with Bang & Olufsen).

Niles has compiled an extensive IR Library of over 175 different products from most of the major manufacturers (including many direct access and separate "On/Off" codes). Earlier versions of the IntelliFile II CD-ROM do not include the extended IR Library, so call Niles Tech Support at 1(800) 289-4434 with your email address and we will email it to you!

Before an IntelliControl installation is proposed to a customer, it is strongly recommended that you check the equipment list for compatibility. As a general rule, if the component's codes are capable of being taught to a standard "learning" remote control (Pronto, RC2000, SL9000, etc.), the IntelliFile II will be able to learn them.

*Note: If a product's codes do not work reliably when taught to a learning remote, "A/B" codes could be the cause. A small percentage of video projectors and other components*

*feature Philips RC-5 codes. This type of IR code structure has been known to exhibit “A/B” behavior in some products, and may be incompatible.*

*To be brief, these products have two different codes for each button on the remote, the “A” version and the “B” version. The product must receive alternating (A/B/A/B, etc.) versions of its codes or it will not respond. It doesn’t matter what code is issued (or in what order), because the remote and the product will keep track (technically there’s more to the story, but this is the basic principle). Since the IntelliFile II (and the IntelliControl MSU) can only store one version of each code in memory, only the “A” or the “B” version can be learned and stored in memory, which creates a problem.*

The following procedure will help you determine if the component you are using is has “A/B” codes:

1. Standing in front of the component, issue the “Power” command to turn it on. *This will theoretically issue the “A” version of the “Power” command.*
2. Next, completely cover the front of the remote with your hand so that the next command you issue will be blocked.
3. With your hand covering the front of the remote, issue the “Power” command again. *This command will theoretically be the “B” version, and should not be allowed to reach the component. The component should remain “On”.*
4. Remove your hand and issue the “Power” command again. *This will once again issue the “A” version of the code to the component.* If the component does not turn “Off” (because it has received two “A” version codes in a row) the codes may be “A/B”.
5. Issuing the “Power” command yet again should turn the unit “Off”. *This would allow the component to receive its “B” version “Power” command, and enable it to work properly.*

Repeat this procedure with a couple of different commands to be sure. Only allow the product to receive every-other command. *If you are convinced the product you are using has “A/B” codes, call Niles Technical Support at 1(800) 289-4434 for assistance.*

## **Testing Components for Automation Conflicts**

All components must be tested to ensure that their operation does not conflict with the goal of automating the system. Try to detect IR codes that have two functions. Sometimes this could help you automate the system (i.e. a direct IR command for a particular input also turns the unit on. This feature is common with some Marantz and Sony receivers).

In some instances, however, they defeat automation (i.e. ADA manufactures a preamp in which the “Mute” command mutes the preamp, but does not unmute it. A second touch of the “Mute” key turns the preamp off).

## **Testing Components for Sync Method**

Each component must be “Sync Tested” to determine if it will correctly signal the IntelliControl that it is on or off, using the sync method specified. You cannot assume that a sync method will work properly. The following notes will alert you to common sync problems encountered in the field.

*Important! Every component, which uses an IR command to turn on or off should be synced to the IntelliControl, and sync, tested for reliability.*

It is a common mistake to omit sync for a component, which uses two separate IR commands – one command to turn “On”, and a different command to turn “Off”. Without sync, the IntelliControl will not know that an “Off” command is necessary when the “System Off” Key is pressed, and the component will not be shut off. Additionally, an unnecessary delay of 2 seconds will occur every time that component is selected with its labeled Master Key, even when the system is already on.

### **Sync Off Delay**

It is common for many video components such as VCR's and DSS receivers to continue to output video for a few seconds (or longer) after they have been turned off. This creates a false sync signal and may interfere with reliable operation. It is important to note duration of the component's “Sync Off Delay”, and discuss this with the installer and the end user.

If a Master Key is pressed immediately after the “System Off” key is pressed, the false sync signal may prevent the IntelliControl from turning on that component. To maintain sync during operation and troubleshooting, it is important that both the installer and the end user know how long they must wait before the system can be turned back on after a System Off command has been issued. This problem can be eliminated by including a delay (of whatever duration necessary) in the Ending Sequence of the “System Off” key.

This problem can reach epic proportions when using an APC-2 to current-sense an LCD projector. Most LCD projectors require the internal fan to stay on for as long as ten minutes after the projector is turned off. This may trigger the current sensing device to send a false sync signal for ten minutes!

Attempt to adjust the current sensing device to reduce the sync delay to a few seconds after the projector is turned off. If this is not possible, change to a different sync method (such as the LS-1 Light Sensor).

### **Testing the Switched AC Outlet**

Make sure that the switched outlet actually switches “On” and “Off” with the component's “power” command. Two 1995 model Harman Kardon receivers (the base model Pro-Logic and the base model stereo receiver) and the 1995 base model Denon stereo receivers advertise “Switched” AC outlets. However these “switched outlets” do not turn on and off with IR commands. They only switch with the front panel “Power” button. For products with this type of “psuedo-switched” outlet, a Niles LS-1 Light Sensor or the APC-2 Current Sensor must be used to provide reliable sync.

## **Testing the Video Output of a Source**

Make sure that the video signal turns off when the component is turned off with an IR command. Some video components output a video signal even when off. This can be difficult to detect with a television since some televisions generate a blue screen when there is no input (which is why use of the TV's "Tuner" output is recommended). To reliably test for video sync, you will need an IntelliControl Main System Unit, the IntelliFile II Programming Software and PC Interface, the RF/IR Test LED, and the Transfer Cable. Follow these steps to test for video sensing:

- 1) Hook the video component to the video sync port that corresponds to its Master Key label.
  
- 2) Connect an RF/IR Test LED to the RF Test port on the Main System Unit.
  
- 3) Power up the Main System Unit.
  
- 4) Power up and connect the IntelliFile II PC Interface to the Main System Unit with the supplied Transfer Cable.
  
- 5) Click on the "Components" tab in IntelliFile II and select the component you wish to video sync test.
  
- 6) Go to "Sync Test" , select "Video Synced", and click the "On" button. (The IntelliFile II will stay in video sync mode for the component being tested until the "Off" button is selected).
  
- 7) Turn the video component "On" and "Off" manually (or with the remote). *The RF Test LED should be green when it is "On", and red when it is "Off".*

If the Test LED displays a red LED when the video component is "On" (or a green light while the component is "Off"...) you must utilize an LS-1 Light Sensor or the APC-2 Current Sensor to provide reliable sync.

## **Testing the Video Output of a Television**

Use the TV's "Tuner" output if the TV is equipped with one. If the TV has only a "Video" or "Monitor" output, will have to resort to another sync method. A TV's "Monitor" output will only give reliable sync if the television's input is never changed to an input without a video

signal present. However, if you select a video input connected to a device that happens to be “Off” (video games, computers, etc.), the IntelliControl will be fooled into thinking that the television is “Off”, when it is, in fact, “On”. Test to be sure. If the “Video” or “Monitor” output is not reliable, use an APC-2 to current sense and provide 12V sync.

### **Testing Light Sensing**

Make sure that some portion of the front panel display dims when the component is turned “Off” with an IR command. If a product were to be manufactured with a display that simply changes color, light sensing sync would not be reliable and an APC-2 or IPC-6 current sensor should be specified.

### **Testing Current Sensing**

Make sure that the APC-2 reliably senses the difference between “Standby” and “On”. The component must have a 30 watt difference between “On” and “Off” (or “Standby” and “On”) to be reliable. If the current difference is less than 30 watts, the IPC-6 Current Sensing Power Manager or the LS-1 Light Sensor should be specified. The IPC-6 can sense a 3-watt difference between “Standby” and “On”.

### **Testing a Component’s Control Voltage Output**

The OTI-512 voltage converter outputs a 12V DC voltage whenever any voltage between 3V and 30V AC or DC is output from the component. Make sure that the component’s voltage output reliably turns on and off in sync with the IR commands. Some components have voltage outputs that are only present when a component is in a particular mode of operation. This will cause the system to get out of sync if it happens to be in another mode. Use a voltage that is present in all modes of operation and is not present when the component is “Off”, or simply specify another means of syncing the device.

### **Testing Dual Zone Preamp/Receivers**

Most dual zone preamp’s switched outlets are not able to provide reliable sync for just the Home Theater zone (unless it only switches on when the “Theater” zone is active and not when “Zone 2” is active). Because of this, it may not be possible to sync the receiver using a 12V DC wall adapter. Instead you must resort to using dual zone receivers with separate “On” and “Off” commands for the “Main” and “Second” zones, configurable control voltage outputs, or simply use two separate receivers. An LS-1 Light Sensor may be used if there is a way to detect when the Home Theater zone is on independent of the Second Zone.

Connect the dual zone component so that you can listen to music on both zones. Turn on the "Second zone", and then turn the "Home Theater" zone "On" and "Off". You may be able to position an LS-1 Light Sensor on the portion of the display that brightens when the Home Theater zone is on. Turn the Home Theater zone "On" and "Off" and observe the LS-1's LED to see if you can get reliable sync (green lights on your Test LED). This test will only be valid if you repeat the test with the display in every possible configuration, with any input selected, and with the Second Zone "On" and "Off".

## Programming Capabilities

### 3A. Pages, Keys, and Sequences

Designing and programming an IntelliControl system requires that you have an intimate understanding of how the IntelliControl functions. This way you can sell the system properly (and not embarrass yourself by making unrealistic promises), as well as be able to quickly and efficiently program the system so the customer gets the maximum amount of enjoyment from his investment. In the following sections, the operational capabilities of each key are described, and the overall architecture of the IntelliControl product is explained.

The IntelliControl's memory is divided in two sections. One section stores all of the "Automation" (including all "Power" commands, "Input Selection", etc.), and the other section of memory is divided into "pages" for storage of all of the remaining IR commands which the user may issue to control the features and functions of the components, as well as peripheral devices in the system.

*Note: It is not important that you learn how to program the functions described below at this time. Simply concentrate on understanding the general concepts, and explicit programming instructions will be explained step-by-step in the IntelliFile II Reference Manual Version 1.0.*

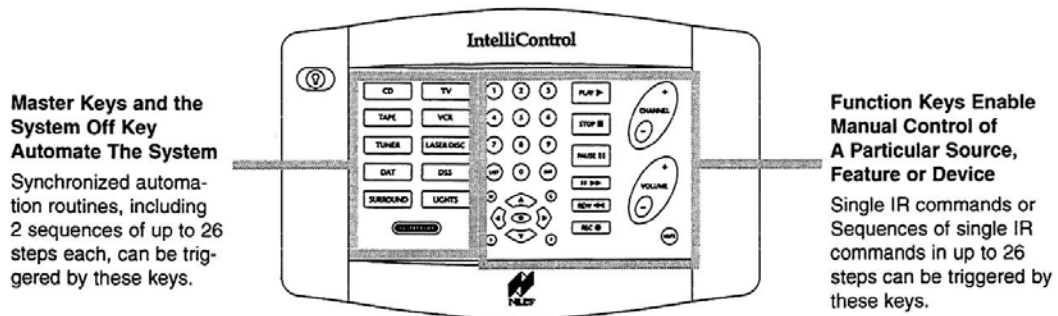

Figure 9 The IntelliControl Tabletop Remote

## **An Address For Every IR Command**

Every command you want the IntelliControl to issue must be stored to a memory address (including commands that are only issued as steps in a sequence). Every memory address is composed of two parts, the “Key” you are pressing, and the “Page” you are on when that “Key” is pressed.

The “Key” is the actual key you would press on the IntelliControl’s Tabletop Remote (i.e. “Play”, “Stop”, “Pause”, “Volume Up”, etc). The “Page” describes one of thirteen different layers of memory storage (there are ten user-accessible “Master Key Pages” for source components or features, plus three additional pages called the “Special Pages”. The “Special Pages” include the “Library 1”, “Library 2”, and “Default” pages, which will be discussed later. *Explicit instructions for programming “Function Key IR” commands can be found in the IntelliFile II Reference Manual starting on page 9.*

Once the ten Master Keys are labeled, all of the keys on the right side of the Tabletop Remote will be referred to as the “Function Keys”. “Function Keys” correspond to the currently selected “Master Key Page”. Not only does the press of a Master Key initiate all of the necessary automation required to enjoy the selected source, it also configures the system to enable you to select any of the “Function Keys” on the right two-thirds of the Tabletop Remote and control the currently selected source. Thus the VCR’s “Play” command is typically stored on the “VCR Master Key Page” in the “Play Key” memory address.

## **Issue A Sequence From A Function Key**

If desired, every “Key” on every user-accessible “Page” may be programmed to trigger either a single “Function Key IR” command, or “Function Key Sequence” of up to twenty-six IR commands. The key that the user will press to issue the sequence is referred to as a “Trigger Key” in the IntelliFile II software. Thus if you wanted the “VCR” page’s “Play” key to issue a sequence, you would consider the VCR page as the “Trigger Page”, and the VCR page’s “Play” button as the “Trigger Key”.

*Note: As previously mentioned, each memory address may be programmed to store a single “Function Key IR” command, as well as to trigger a “Function Key Sequence” if programmed to do so. Therefore, a “Function Key Sequence” may be triggered by tapping a Function Key (i.e. by pressing the “Play” key on the “VCR” page).*

However, the “Function Key Sequence” will always take priority. The actual “Function Key IR” command stored to the “Play” key address is not erased, and may be included in this sequence (or any other sequence). This means that if you want the VCR’s “Play” command to be issued as one of the steps in a “Function Key Sequence”, the VCR “Play” command must be included as one of the steps when the sequence is programmed.

When a “Function Key” is pressed, the IntelliControl first checks to see if a “Function Key Sequence” has been programmed to be triggered by the selected Function Key. If a sequence has been programmed, it will be initiated. If a sequence has not been programmed to be initiated by the selected Function Key, the single “Function Key IR” code stored to that “Page” and “Key” address would be issued.

Therefore, you could first program the “Play” key on the “VCR” page with the VCR’s “Play” Function Key IR command (which plays the VCR), then you could program the same key to issue a sequence consisting of two steps - the VCR’s “Play” command, followed by the LIGHTS “Dim” command. Note: Each actual step has two parts, “a” and “b”. The overall flow is as follows:

- 1a. Identify the “MASTER KEY PAGE” on which the “Trigger Key” that will trigger our sequence is located. *In this example we will select the “VCR” Master Key.*
- 1b. Identify the “TRIGGER KEY” (on the currently selected page) that will trigger our sequence. *In this example we will select the “Play” Function Key.*
- 2a. Identify what “PAGE” the FIRST command in our sequence is stored on. *In this example, the “Page” (where the first command is stored) will be the “VCR” Page. This will be the same “page” as Step 1a, but ONLY if the first command in the sequence will be the same as the sequence trigger.*
- 2b. Identify what “KEY” (on the currently selected page) the FIRST command in our sequence is stored on. *In this example, the “Play” button is where the first command in our sequence is stored. This will be the same “key” as Step 1b, but ONLY if the first command in the sequence will be the same as the sequence trigger.*
- 3a. Identify what “PAGE” the SECOND command in our sequence is stored on. *In this example, the “Page” (where the second command is stored) will be the “LIGHTS” Page.*
- 3b. Identify what “KEY” the SECOND command in our sequence is stored on. *In this example, the “#1 digit” is where our second command is stored. (In this example, the actual code will be a Lutron Grafic Eye scene command that has been stored on the “Lights” Master Key page, to the “#1 digit” Function Key location).*

If your sequence consists of more than two steps, simply repeat steps 3a and 3b. The concept of sequence programming is very straightforward as long as you always think of each step as having two parts, the “Page” and the “Key”.

*Note: This is the exact same concept used with the Niles IntelliPad Programmable Keypad, and applies to both manual programming and programming using IntelliFile II for IntelliPad.*

## **Purpose of the Master Key Pages**

The ten Master Keys decide which “page” of IR command memory will be accessed. When a Master Key is pressed, the Function Keys (on the right side of the remote) now access that page of IR command memory. For example, when the “VCR” Master Key is pressed, the “Play” key will play the VCR, and when the “DVD” Master Key is pressed, the “Play” key will play the DVD. There are ten labeled Master Keys, each selecting a page of memory with up to 32 individual IR commands on each page. This gives you a total possible 320 addresses for IR commands for manual operation of the components in the system.

## **Purpose of the Default Page**

If you choose not to program a “Function Key IR” command or a “Function Key Sequence” to any specific key on any of the ten Master Key pages, the IntelliControl will automatically

look to that memory address location on the “Default” page of memory to see if a “Function Key IR” command (or a “Function Key Sequence”) is stored there. If there is information programmed to that particular address on the “Default” page, the IntelliControl will issue whatever code (or sequence of codes) is stored there.

Therefore, the “Default” page is the memory location for IR commands that are universal to all of the components in the Home Theater system. An example of this would be the Preamp/receiver’s “Volume Up and Down”, and “Mute” commands. You simply do not program any IR commands to the “Volume Up/Down” and “Mute” Keys on the ten source pages, and let the IntelliControl issue the commands stored to those locations on the “Default” page.

If the user constantly adjusts picture or surround-sound, you could choose to assign the “Menu” group of keys as a universal feature, so that no matter what Master Key is currently selected, the “Menu” keys will access the customer’s desired functions.

### **Purpose of the Library Pages**

There are two additional pages of memory addresses called “Library 1” and “Library 2”. The “Library” pages are only used to store codes, which will be included in sequences. Codes taught to the Library pages are not directly accessible by the end-user (unless they are included in a sequence, of course!).

## **3B. Master Key Automation: Part 1 - One Touch System Turn On**

By pressing a Master Key, the end user will trigger the following programmed “Events” to occur. These events are displayed in the “Master Key Navigator” feature of the IntelliFile II software. The “System Turn On” automation will power up and configure the home theater system based on the actual status of the components at the time the Master key was pressed.

*Note: “System Turn On” automation is an automatic function of the IntelliControl System. DO NOT attempt to manually program the “System Turn On” automation by including the TV, Preamp, and Component power commands in the “Initial Sequences” for the Master Keys. This will bypass all the sync features and the built-in intelligence which has made the IntelliControl such a successful product.*

*The “TV Power”, “Preamp Power”, and “Component Power” commands are entered on their respective “Tabs” in the IntelliFile II software. The appropriate “Power” commands are automatically issued based on the “Audio Scene”, “Video Scene”, and “Component Power” programming which is configured on the “Components” Tab in IntelliFile II. For more information, see **Scene Setting** on page 25 of the IntelliFile II Reference Manual.*

## Sync Snapshot

As soon as a Master Key (or the “System Off” Key) is pressed, and before any commands are issued, the IntelliControl MSU takes a “Sync Snapshot” of all the sync ports on the MSU. By taking this “Snapshot”, the MSU is essentially taking inventory (roll call!) to determine exactly which components are on and which components are off at the exact moment the Master Key was pressed.

The MSU then takes the information it gathers during the “Sync Snapshot” and compares it to the automation information you have programmed for that Master Key. The IntelliControl will then intelligently reconfigure the system to enable the user to enjoy the selected source. This automation programming can be viewed via the “Master Key Navigator” feature by clicking on the **View** button next to each Master Key name on the “Master Keys” Tab in IntelliFile II. The “Navigator” contains the entire set of programming instructions that must be executed in order for the user to enjoy the selected source.

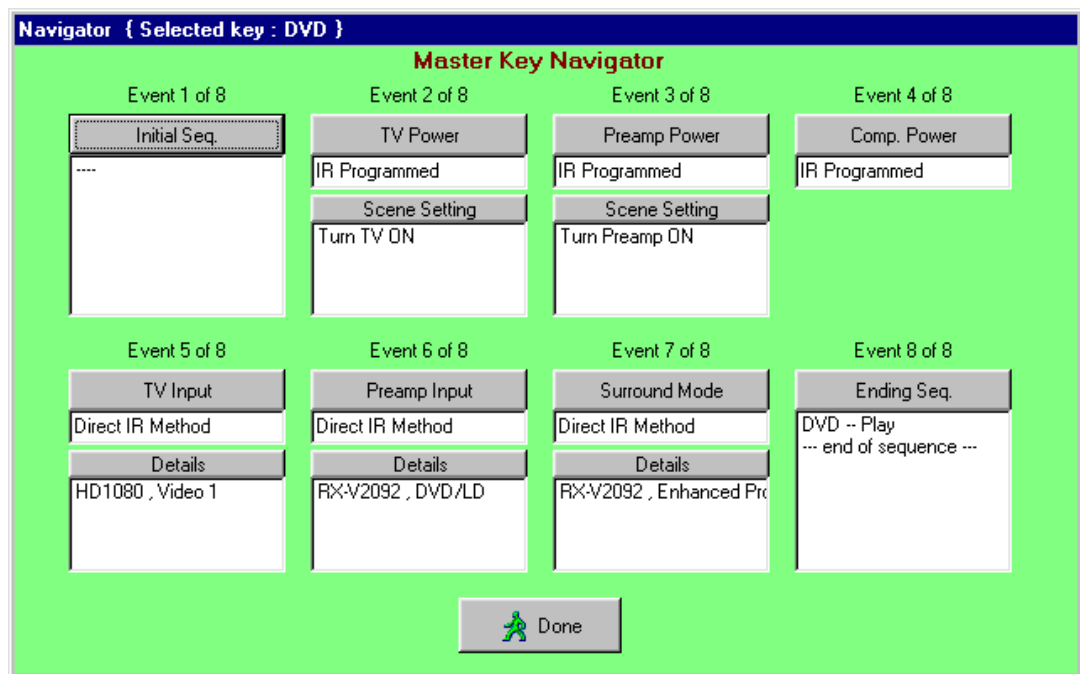

Figure 10 The Master Key Navigator

## Event One – Initial Sequence

The “Initial Sequence” is issued without regard to sync, and is generally used to issue commands to peripheral devices in the system (i.e. screens, lifts, drapes, masking devices, lighting controllers, etc.).

*Note: “Power”, “Input” and “Mode” commands should not be placed in the “Initial Sequence”, as these commands will be issued without regard to sync.*

## **Event Two - TV Power**

In “Event Two – TV Power”, the IntelliControl checks the automation programming of this particular Master Key. Should the TV turn “On” when this Master Key is pressed? Should the TV turn “Off” when this Master Key is pressed?

Once the IntelliControl has checked it’s instructions, it refers to the “Snapshot”. If the “On/Off” status of the TV is different from the instructions, the IntelliControl will issue the necessary “Power” command to the TV .

## **Event Three - Preamp Power**

When the IntelliControl reaches “Event Three, Preamp Power”, the IntelliControl checks the automation programming for this particular Master Key. Should the Preamp turn “On” when this Master Key is pressed? Should the Preamp turn “Off” when this Master Key is pressed?

Once the IntelliControl has checked it’s instructions, it then refers to the “Sync Snapshot”. If the actual status of the Preamp is different from the instructions, the IntelliControl will issue the necessary “Power” command to the preamp.

## **Event Four - Component Power (Not Applicable to Master Keys Nine and Ten)**

When the IntelliControl reaches “Event Four, Component Power”, the IntelliControl will first check the programming of this particular Master Key. Should the chosen component turn “On” when this Master Key is pressed?

Once the IntelliControl has checked it’s instructions, it then refers to the “Sync Snapshot”. If the “On/Off” status of the component is different than that of the instructions, the IntelliControl will issue the necessary “Power” to turn on the component.

## **Event Five - TV Input**

The IntelliFile II software features three methods to change the TV’s inputs. See details starting on page 32 of this manual.

## **Event Six - Preamp Input**

The IntelliFile II software features three methods to change the Preamp’s inputs. See details starting on page 32 of this manual.

## **Event Seven - Surround Mode**

The IntelliFile II software features three methods to change the surround-sound modes on the preamp. See details starting on page 32 of this manual.

## **Event Eight - Ending Sequence**

The “Ending Sequence” is used to issue commands that need to be issued after the IntelliControl has turned on the components and selected inputs and modes. IR commands included in the “Ending Sequence” are issued without regard for sync.

Typically, “Play”, “Digit” commands (used to select the users favorite channel), and occasionally “Stop” commands (for other components in the system) are included in the “Ending Sequence”.

## 3C. Master Keys: Part 2 - Special Features

### Automation Bypass for Manually Adjusted Features

Additionally, you may choose to utilize the IntelliFile II’s “Automation Bypass” feature by selecting **Leave TV Alone** and **Leave Preamp Alone** under “Scene Settings” on the “Components” Tab.

The IntelliFile®II’s “Automation Bypass” feature would be useful if you wanted a certain Master Key to be used as a “Feature Key”. Setting a Master Key up as a “Feature Key” enables it to control devices or functions which are *not* source components, but simply functions of a source, or functions of a peripheral device (i.e. a lighting control system, mechanical drapes, projection screen, masking devices, etc.).

After the “Feature Key” has been selected and the desired commands have been issued from the “Feature Key” page (“single” IR commands or a “Function Key Sequence” may be issued from the “Feature Key” page), you are able to reselect the original Master Key for the source you are watching to regain control over the functions of that source. The system will not reconfigure itself to the original Master Key’s default settings.

*Note: If a different Master Key (other than the one selected before the Feature Key was pressed) is chosen, the “Automation Bypass” feature will not work as described, and the system will reconfigure itself to its default settings for the newly selected Master Key.*

By configuring a Master Key as a manually controlled “Feature Key”, the “Automation Bypass” feature becomes a useful part of a system design whenever manual control of the system’s features (as well as automation) is desired.

### Automation Bypass for a Typical Application

Normally, when the “CD” Master Key is pressed, the IntelliControl® will set the system’s Surround Sound Mode to “Stereo”. However, you may label one of your Master Keys as a “Surround Sound Feature Key” so the end-user may select a source and then manually change the surround mode from its default setting.

This is accomplished by programming the “Surround Sound” Master Key to **Leave the TV alone** and **Leave Preamp alone**, which will enable the “Automation Bypass” feature. You then program the IntelliControl®’s numeric keys on the “Surround Sound” page to enable direct access to the preamp’s different DSP surround modes (i.e. Concert Hall, Stadium, Jazz Club, etc.).

A typical listening session might go something like this: You press the “CD” Master Key and the system comes to life correctly configured to Stereo Mode. After listening for a while, you decide that one of your processor’s digital sound fields would be very well suited to the CD you are listening to. You press the “Surround Sound” Master Key and experiment with different modes until the sound is perfect.

However, if the user decides to skip a song on the CD, you simply reselect the “CD” Master Key to access the song skip button. Normally this would reset the system to Stereo, but since the “Surround Sound” Master Key was programmed as a “Feature Key”, the IntelliFile II’s “Automation Bypass” feature is engaged, and the preamp will not be reset to Stereo mode.

Since the “CD” Master Key was the last source selected before pressing the “Surround Sound” Master Key, the normal steps the CD Master Key would trigger to reset the surround mode to “Stereo” are bypassed. If you were to press any of the other Master Keys (rather than the last selected, which would be “CD” in this example), the automation would not be bypassed and the system would continue with normal operation and configure the system to the default surround mode for that newly selected Master Key.

### **How to Program “Component Power” for Multiple Master Keys which Share a Common Source**

It is possible to use more than one Master Key to automatically turn on and control the same source. One example might be multiple Master Keys (labeled HBO, Showtime, Disney, ESPN, etc.) that are all turning on and controlling the same DSS receiver. However, the ending sequence for each of the Master Keys is programmed to select a different channel.

Another example would be a system with a Pioneer combination DVD, Laser and CD player. You would label three Master Keys for the three functions in the machine, so that you can program the Surround Sound Mode to be “Dolby Digital” when the DVD key is pressed, “Dolby ProLogic” when the Laser Disc key is pressed, and “Stereo” when the CD key is pressed.

There is an “Installation Trick” and a “Programming Trick” which need to be performed in order for the component to turn on and off as the end-user would expect:

#### **Installation Trick**

You must split the shared source component’s sync output to each of the appropriate sync connections for each Master Key that will be used to automate and control the shared component. This will enable the MSU to accurately monitor the sync status of the shared source from any of the Master Keys.

## **Programming Trick**

*Note: this "Programming Trick" is only necessary if the component being shared utilizes a single "Toggle" power command to turn the unit "On" and "Off". If the component you are using features "Separate on and off" commands, simply program each Master Key as you normally would.*

The IntelliControl Tabletop Remote features ten Master Keys, which are numbered 1 through 5 in the left column, and 6 through 10 in the right column.

For the Master Key with the lowest number (out of the IntelliControl's ten possibilities), program the component's "Power" command in the standard way. Meaning that on the "Components" tab in IntelliFile II, when the you are asked whether the component uses a single "Toggle" command, or "Separate On/Off" power commands, answer "Toggle" (one "single" power command).

For all of the other Master Keys with higher numbers (out of the IntelliControl's ten possibilities), which will automatically turn on the shared source component, choose "Separate On/Off".

Even though the component only features a single "Toggle" power command, this technique will enable us to trick the IntelliControl into proper operation by programming the component's "Toggle" power" IR command into the "On" location, and a bogus IR command (such as "play", or any command belonging to a component not being used in this system) in the "Off" location. *Note: Once again, this programming "trick" is unnecessary if the component uses separate "On" and "Off" commands.*

## **Press and Hold a Master Key**

Optionally, the ten labeled Master Keys may be programmed to trigger an additional "Function Key IR" command, or a "Function Key Sequence" of up to 26 steps, whenever a Master Key is "pressed and held" for more than one second.

This function of the system is completely independent of the Master Key automation programming that occurs when the Master Key is simply "tapped". *Note: If the system is not active when a Master Key is pressed and held, the normal intelligent automation programming will be bypassed, and only the "Press and Hold" IR command (or sequence) will be issued.* Additionally, this IR command (or sequence) will be issued without regard to sync.

Typically the "Press and Hold" feature is used to provide the end user with a way to manually turn a particular component "On" or "Off". It is frequently only programmed for the TV Master Key, so that the user can turn on the system with a video source (automatically switching on the TV), then switch to listening to an audio source (the TV could be programmed to remain on), and then finally decide to continue to listen to the audio source with the TV "Off" by pressing and holding the TV Master Key. The installer has programmed the "Press and Hold" function of the TV Master Key to issue the TV's "power" command when that key is pressed and held.

Should the end user desire the ability to manually issue "Power" commands to all of his IR controlled sources, each of the Master Keys could be programmed via the "Press and

Hold” feature with the IR “power” command for each source. Once again, the “Press and Hold” feature may also be used to initiate a sequence of up to 26 commands (including delays and contact closures/openings) from any of the ten Master Keys.

### **Custom Programming for Preamp/Receivers with Separate On/Off Commands**

Several manufacturers are currently offering preamps/receivers with cool features like “main” and “second” zone capability, separate “On” and “Off” commands for these zones, as well as rear-panel hardwired IR inputs for each zone.

This enables you to custom program the IntelliControl by not programming “Preamp Power” the traditional way, but instead by teaching the “On” and “Off” codes to the “Library” pages so that the Preamp’s “Separate On” command can be added to the “Initial Sequences” of every Master Key. You may then include the “Off” command as a sequence step to the “System Off Initial or Ending Sequence”.

## **3D. Master Keys: Part 3 - Direct IR, Sequence IR, and Managers**

One of the key automation features of the IntelliControl is its ability to select Preamp and Television “Inputs” and “Modes” three different ways:

### **Direct IR - A Different “Single” IR Code for each of the Component’s Inputs.**

This is the most desirable type of preamp, television monitor, or projector to automate. Access to inputs is quick and absolutely reliable. The end user may freely use the component’s original remote control as well as the IntelliControl.

#### **Testing Direct IR**

Try each of the IR input commands twice. If any of the input commands act like a “toggle” on the second push (and actually switch the television back to another input), “Direct IR” input selection will not be reliable. If some of the IR input commands do not toggle, consider routing the components to only those TV inputs that do not “toggle”, leave the other inputs that do “toggle” unused.

### **Sequence IR— a Single “Input Toggle” Command and a Secret Back-Door “Anchor” Command(s)**

This is a very desirable type of preamp, television monitor, or projector to automate. The “Anchor” IR command (or series of commands) takes the device to a known input, then a sequence containing the required number of “Input Toggle” commands is issued to take the device to the correct input for the source selected.

Access to inputs will be delayed up to 2.5 seconds for some sources (if 5 input changes were programmed into a sequence). “Sequence IR” input selection is absolutely reliable. The end user may freely use the component’s original remote control as well as the IntelliControl.

## **Finding the Secret Back-Door “Anchor” Command**

Most manufacturers do not acknowledge the existence of “Anchor” commands. Basically, it is an IR command (or sequence of IR commands) that has some other normal purpose, but the manufacturer has designed the device to go to a specific input (or execute a specific function) when this command is given, regardless of what input the component is currently in. These functions are typically reserved for use by factory service technicians or engineers.

The most common television input “Anchor” commands are “Channel Up”; “Channel Down”; “0,0,ENT”; “9,2,ENT”; “9,1,ENT”, but there are several others. When you test a new television model, use your imagination when trying various code combinations, since each manufacturer has their own ideas as to what is effective.

## **Testing the “Anchor” Command**

Once you have found the anchor code(s), they must be tested. Make sure that no matter what input the component is in, issuing the anchor code will select the specific anchored input *every time*. If the anchor is not 100% reliable, you will have to resort to using the “Input Manager” method.

## **Input Manager – For Components with only a Single “Input Toggle” Command**

This is the least desirable type of preamp, television monitor, or projector to automate. Using the “Input Manager” method, the system will be able to keep track of what input the component is in at all times, even through repeated power failures and system power ups.

Whenever the end-user selects a new Master Key, the IntelliControl will calculate the required number of “Input Toggle” commands necessary to change the device from whatever input it is currently on, to the appropriate input required to enable the customer to enjoy the newly selected source.

## **Testing the “Input Manager” Method**

The “Input Manager” is NOT RELIABLE unless the end user cannot use the component’s original remote control, or access the “Input Toggle” key on the front panel of the component (if it has one). If you cannot block access to the front panel, or the customer has identical branded televisions with remotes throughout the house, the likelihood of sync problems created by the end user is extremely high. In such an installation, the “Input Manager” method should not be used, and a Master Key should be labeled “TV Input” so that the end-user can manually change the inputs.

## **Determine the “Defaults”**

In order to determine the “Defaults”, the way the component functions under the following circumstances must be noted in IntelliFile II. By simulating a power failure on at least two of the inputs, does the TV remember the last input selected? Or does it go to a particular input when the unit regains power? Now, do the same test, but turn the component “On” and “Off” normally. Does the TV remember the last input selected? Or does it go to a particular input every time?

## 3E. Master Keys: Part 4 – Intelligent System Turn Off

When the “System Off” key is pressed, the IntelliControl takes a “Snapshot” to determine which components need to be turned “Off”. The system then issues only the necessary commands to power down the components which were “On” when the “Snapshot” was taken. The following “Events” occur after the “Sync Snapshot” is taken:

### Event 1 - “System Off” Initial Sequence

An “Initial Sequence” of up to 26 steps may be issued to reconfigure any devices to their default positions before the system is powered down.

*Note: The IR commands used to power off all of the components in the system are automatically issued from the “Preamp”, “TV”, and “Component” power memory addresses on their respective Tabs as programmed via IntelliFile II.*

### Event 2 - TV Auto Turn Off

If the TV is on when the “System Off” key is pressed, this step turns it off.

### Event 3 - Auto Volume Reset

The volume of the Preamp may be automatically lowered to minimum, then raised to any level you choose.

*Note: This feature requires that the preamp’s “Volume Up/Down” commands be taught to their respective Function Key addresses on the “Default” page of memory using IntelliFile II software. You can customize this feature to the Preamp you are using by determining the duration of the “Volume Down” command (issued to bring the Preamp’s volume to absolute minimum), and then the duration of the “Volume Up” command (issued to bring the Preamp’s volume up to whatever level you decide is appropriate).*

### Event 4 - Preamp Auto Turn Off

If the Preamp is on when the “System Off” key is pressed, this step turns it off.

### Event 5 - Component Auto Turn Off

All components, which show sync when the “System Off” key is pressed, are turned off.

### Event 6 - “System Off” Ending Sequence

An “Ending Sequence” of up to 26 steps may be issued to reconfigure any peripheral devices to their default positions after the system is powered down.

*Note: The IR commands used to power off all of the components in the system are automatically issued from the “Preamp”, “TV”, and “Component” power memory addresses on their respective “Tabs” as programmed via IntelliFile II.*

## **3F. The Audio, Video, and Assignable Relays with Control Voltage Output**

The IntelliControl enables you to control devices that are triggered or operated via 12v DC control voltages or normally open / normally closed dry contact closures. There are three relay groups: Audio, Video, and Assignable. More than one device or function can be triggered (turned on) by the same relay group.

### **Relay Voltage Limitations**

There is a 300mA limit to the combined output of all of the 12V DC control outputs. Add up the combined draw for all devices triggered by the Audio, Video, and Assignable control voltage outputs. If the total combination is within the limit, it is acceptable to trigger more than one device from any one-control output.

Those devices, which draw more current than the IntelliControl can supply, should be triggered by a wall adapter or power supply of adequate capacity routed through the contact closures. *Note: The contact closures are rated to a maximum of 30 volts AC or DC with a maximum current of 1 amp.*

*Also Note: Never connect 120V AC to the contact closures. Use a Niles AC-6+ triggered by a 12V DC control voltage for AC Power Switching. The Niles AC-6+ consumes 100mA of current when triggered.*

### **Audio 12V Output**

The Audio 12V Output is automatically activated whenever the Preamp is "On". This is configured in the IntelliFile II software, on the "Components" tab for each Master Key, by selecting "Turn Preamp On" in the "Audio Scene Setting".

### **Video 12V Output and Relay**

The Video 12V Output and Relay are automatically activated whenever the TV is "On". This is configured in the IntelliFile II software, on the "Components" tab for each Master Key, by selecting "Turn TV On" in the "Audio Scene Setting". It is not possible to activate the 12V Output without activating the Relay, and vice-versa.

### **Assignable 12V Output and Relay**

The Assignable 12V Output and Relay are controlled with two dedicated commands, "Relay On" and "Relay Off" which are found in the IntelliFile II programming software. The functions of the Assignable Relay can only be activated (or deactivated) as a step in a sequence. Once again, it is not possible to activate the 12V Output without activating the Relay, and vice-versa.

However, you may program any two Function Keys on any Master Key page to manually trigger the Assignable 12V and Relay “On” or “Off” by creating a sequence consisting of just one step if desired, which would be either the “Relay On” or “Relay Off” command.

The Assignable relay can be configured as a “momentary contact” by issuing the “Relay On” command as the first step, then the “Relay Off” command as the second step in the sequence. See page 13 of the IntelliFile II Reference manual for more information.

## 3G. Utilities

### ID Code

The IntelliControl Tabletop Remote features four DIP switches located behind the batteries inside the battery compartment.

Select the “Utilities” Tab in the IntelliFile II software and make sure that the Unit ID on the Tabletop Remote matches the Unit ID configuration in the software. It really doesn’t matter which way the DIPswitches are set, as long as they are set the same. Up to 16 IntelliControls maybe used within a 100ft radius if each unit is set to a different Unit ID Code.

### Volume Reset

The “Volume Reset” feature enables you to configure the system to automatically lower the volume to minimum and raise it to any desired level when the “System Off” key is pressed.

*Note: This feature will only work if the Preamp’s “Volume Up” and “Volume Down” commands are taught to the “Volume Up” and “Volume Down” keys on the Default page.*

In the IntelliFile II software, program the appropriate commands to the “Default” page as described in “Step 3 – Program Function Key IR Commands and Sequences”. Then, press the **Edit** key on the “Utilities” page, and adjust the appropriate slider to set the duration of the “Volume Down” and “Volume Up” commands in order to reconfigure the system to turn on to a comfortable level.

### IR Routing

Enabling the “IR Routing” feature allows you to program up to eight components with identical IR codes. *Note: A complete description of the IR Routing feature is detailed in the IntelliFile®II help file.*

**When IR routing is enabled, the system will operate as follows:**

1. All “Component Power” commands as well as “Function Key IR” and “Function Key Sequence” commands taught to the selected Master Key page are issued from that Master Key’s flasher port only.
2. When enabled, “IR Routing” effects IR codes issued from Master Key flasher ports 1 through 8 only!
3. Commands taught to the Function Keys on Master Key pages 9 and 10 as well as all Commands on Library pages 1 and 2 come out of all flasher ports, even with “IR Routing” enabled.
4. “TV Power”, “Preamp Power”, “TV Input Select”, “Preamp Select”, and “Preamp

Surround Mode Select” commands as well as all Function Key commands taught to the Default page come out of the TV, Preamp, Master Key 9, and Master Key 10 flasher ports only.

5. Any data received at the MSU’s “Home Theater IR” or “Second Zone IR” inputs will not be routed. *All codes will be issued via all flasher ports all the time, regardless of IR Routing.*

***When IR Routing is disabled, the system will operate as follows:***

1. All codes come out of all flasher ports all the time.

## **Dual TV**

Enable the “Dual TV” feature to accommodate a system using two TV’s (i.e. both a direct view TV and projector in a home theater). Program as described in the IntelliFile II Reference Manual “Step 5 – Program Dual TV”.

In a Dual TV system, one television is designated the “Default” or favorite TV. It is assigned to the TV sync and flasher connections. The second television is assigned to Master Key 1’s sync and flasher connections. The label you use for Master Key 1 should be “Switch TV”, “TV/Proj”, or “Swap”.

In a Dual TV system, all video switching should be done through the preamp, and the output split to both TVs. Only one TV will be on at a time, so there will be no signal degradation.

If the system is completely “Off”, a Dual TV system will turn on the “Default” TV if any video Master Key is pressed. If the user presses “Switch TV” (Master Key 1) the “Default” TV will turn off and “TV2” will turn on. Until the “System Off” key is pressed, “TV2” will remain on, regardless of what video source is selected. If the user presses the “Switch TV” Master Key again, “TV2” will turn off, and the “Default” TV will turn back on.

*Note: The Dual TV feature does not enable you to watch both TV’s at the same time. If this type of operation is desired, one of your Master Keys should be dedicated to the secondary television and it should be treated as another source component. “IR Routing” must be enabled if the two TVs are the same brand.*

*Also Note: In the IntelliFile II’s “Audio Scene Setting” feature, if an “audio only” source is programmed to “turn the TV off when this Master Key is selected”, whichever TV is currently on will be turned off. The next time any video Master Key is selected, the “Default” TV will turn on.*

## **Mute Manager**

The “Mute Manager” feature enables you to automate the preamp’s “Mute” command so that it automatically unmutes the system when any Master Key or Function Key is pressed.

*Note: The Preamp’s “Mute” command must be programmed to the “Mute” Function Key on the “Default” page of memory.*

---

## Integrating the IntelliControl® with IR Repeater Systems

### 4A. Using Your Original Remote Controls via an IR Repeater System

If the components are not in the direct line of sight of the user, the original component remote controls will be inconvenient to operate. The IntelliControl MSU has a “Home Theater IR” input connector, to enable the connection of a Niles IR Sensor for manual IR control.

*Note: The IntelliControl has two hard-wired IR inputs. The “Home Theater IR” port passes IR to all flasher outputs, even with the “IR Routing” feature enabled. The MSU’s “Second Zone IR” input will pass IR through flasher ports 1 through 8 only, but will do so regardless of “IR Routing”. If you have multiple same-brand TV’s, CD changers, or satellite receivers using the same IR codes, these devices will all receive commands from the IR sensor at the same time. Independent control will not be possible via remote unless you are using an IR Routing device. Unfortunately, Niles does not offer an IR Routing device at this time.*

#### Integrating a Second Zone

The “Second Zone IR” input on the IntelliControl Main System Unit may be connected to the “IR Data Output” of any Niles IR Sensor, Main System Unit, or Multi-room Controller. This will enable both the Home Theater and the whole-house music system to share source components.

*Note: The IntelliControl MSU should remain the primary repeater system for the shared sources.*

Ideally, a separate preamp/receiver, rather than the second zone of a “Dual zone” preamp/receiver should control the whole-house music system. This eliminates some of the limitations and frustrations these systems create (i.e. sync problems, having to share a tuner, etc.). This creates what is commonly referred to as a “True Dual-Zone” system, consisting of two completely independent listening zones, the “Home Theater” zone and the “Whole-House” zone.

*Note: Connecting the “Data Out” connection from your whole-house repeater system to the MSU’s “Second Zone IR” input will enable you have control of your shared sources, as well as the ability to use “same-brand” receivers for the “Home Theater” and “Whole-House” zones.*

Information fed into the MSU from the whole-house repeater system will only be output through flashers 1 through 8 on the IntelliControl MSU. IR fed in via the MSU's "Second Zone IR" input will not be passed to the flasher outputs dedicated to the "Preamp", the "TV", or through flasher outputs "9" or "10".

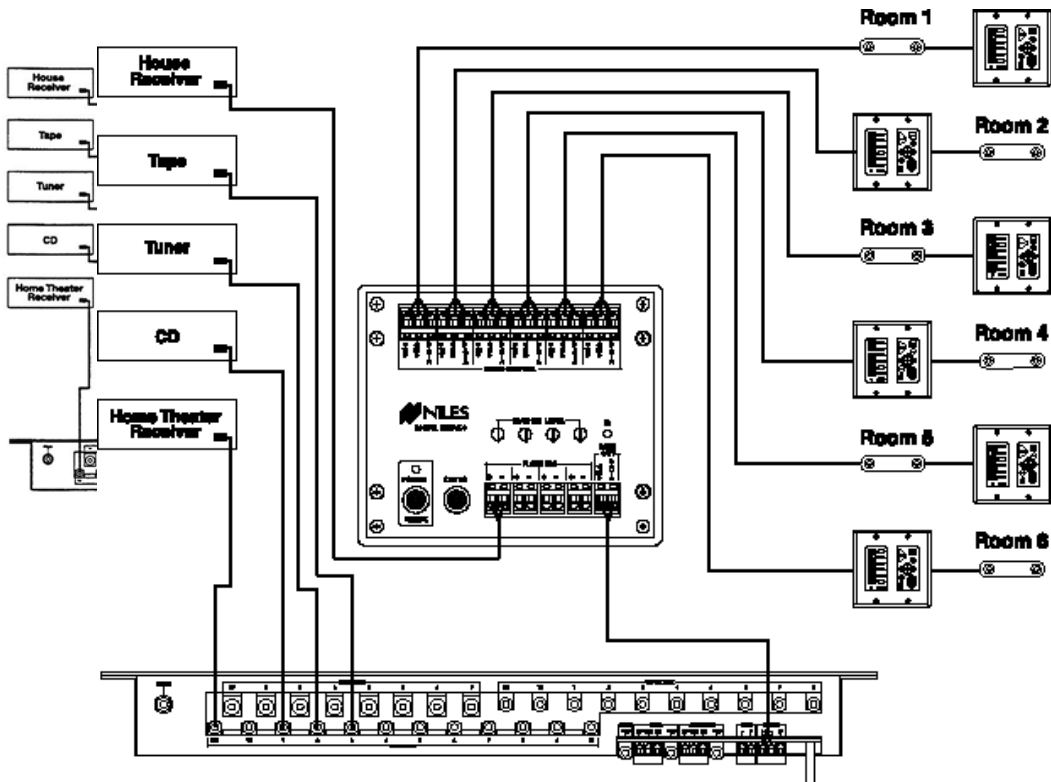

**Figure 11** The "IR Data" output of the IR Main System Unit (IRP/IRZ) is routed to the "Second Zone IR" input of the IntelliControl MSU. IR commands received at this terminal will be output through the MSU's flasher ports 1 through 8 only, and will flash those source components shared by both systems.

An IRC-2 Flasher is connected directly to the IR Main System Unit's flasher output and attached to the second zone receiver.

### Turning On Common Sources in Multi-Zone Systems

It is possible to share sources between a whole-house music system and the IntelliControl Home Theater System. Those sources with latching power may be left "On" all the time, or plugged into a Niles AC-6+ (or any other Niles iPower product). The AC-6+ features two diode-isolated 12V trigger inputs, can be fed by the IntelliControl's "Audio 12V" control voltage output, and a 12V control voltage created by the whole-house music system. Typically, the control voltage for the second zone is created by plugging a 100mA (or larger) 12V DC wall adapter into the switched outlet of the second zone preamp/receiver. *Note: The IntelliControl's Control Output is diode-isolated internally.*

## **Integrating the Niles RVL-6 and MRZ-6 Multi-Room Controllers**

The RVL-6 and MRZ-6 both feature an “IR Data Output” which can be connected to the IntelliControl’s “Second Zone IR” input for control of shared sources.

Additionally, both the RVL-6 and the MRZ-6’s control outputs incorporate blocking diodes in case if you are not using a Niles iPower device.

## **Multiple TV Array In A Media Room**

With the help of an IR Routing Device, multiple identical TVs (or other components) may be controlled with one Master Key. The IR codes used to select the individual routes may be taught to the “Menu” or “Transport” group of Function Keys on the selected “TV Array” page, and the television’s tuner codes are taught to the Numeric and Channel Function Keys.

The system can be programmed so that when the user presses one of the transport keys, the IR Router turns off all flashers except the route you have intentionally selected. Now, when the user operates the “Channel Up/Down” and “Numeric” keys, the IR commands are routed to only that TV (or component).

Unfortunately, Niles has discontinued the IRD-8 product, but similar IR routing devices are available from other manufacturers.

## **Integrating the Niles IntelliPad™ Into the Home Theater**

A wall-mounted IntelliPad is a valuable addition to an IntelliControl Home Theater System. It offers an automated control, which cannot be hidden or misplaced by children or absent-minded adults. Control via the IntelliPad is limited to six of the ten Master Keys.

The IntelliPad must be taught special Niles IntelliControl IR codes (which function the same as the RF automation codes the IntelliControl Tabletop Remote sends). The special IntelliControl IR codes can be found in the IntelliFile II’s IR Library under “Niles” codes.

## **Integrating a Learning Touchscreen Into An IntelliControl Home Theater**

A learning IR remote or touchscreen may operate an IntelliControl Automated Home Theater System. It will not offer the same degree of convenience that the omni-directional, long range, radio frequency control the IntelliControl remote offers; however, your user may have already purchased one of these expensive devices.

The IntelliControl will automate the operation of the Home Theater (the IntelliControl MSU stores all the IR commands and issues all IR codes and sequences), leaving the touchscreen only one job to do: which is to tell the IntelliControl MSU what the user wants to do.

The learning remote (or touchscreen) must be taught special Niles IntelliControl IR codes (which correspond to the RF codes the IntelliControl Tabletop remote sends) by utilizing the Niles IR codes provided in the IntelliFile II IR Library under “Niles” codes.

Learning IR touchscreens issue IR codes, therefore a Niles IR sensor must be connected to the IntelliControl's "Home Theater IR" input.

### **Teach the RF/IR Conversion Codes for the Master Keys, Function Keys, and System Off Key**

*Note: Every RF command sent by the IntelliControl identifies the last Master Key pressed by the end user. For example; if the IntelliControl was busy executing the turn on sequence for the DVD and the end user pressed the Master Key for the VCR, the Test LED would light red to indicate that the system was busy.*

*Additionally, the command would be ignored by the system, but the remote's backlighting would indicate that the system was playing the VCR, however the system is actually playing the DVD. Any key press will correct the problem! The end user does not have to press the VCR Master Key again.*

Thus, the IntelliControl issues 331 different RF commands. You must teach the VCR's "Play" key on your IR learning device the "Play" command which corresponds to the Master Key page dedicated to the VCR in the IntelliControl system. Remember to do the same with "Volume Up" and "Volume Down".

---

# Installing the IntelliControl® Home Theater Automation System.

## Step-by-Step Installation of a New System

### 1. Connect, Power Up, and Test The Home Theater

Make sure that all components work with their factory supplied IR remotes and that all planned input/output connections are correct. It is suggested that you replace the batteries if any remote shows reduced range or intermittent operation. Additionally, best results will be achieved if you are using fresh, high quality alkaline batteries when teaching codes to the IntelliFile II.

### 2. Check MSU Location for Freedom from Interference

Unpack the Main System Unit and place it in a convenient location. You may set the MSU upright on a shelf, mount it to a wall, to the back of a cabinet, or install it into a 19" rack using the optional rack mounting kit (FG00730).

Try to avoid placing the MSU near any known sources of RF interference. Sources of trouble may include DSS Satellite Receivers, DVD players, and/or Digital to Analog Converters - The high-speed microprocessors in these devices produce RF interference in a sphere of a few feet surrounding the unit. Try to locate the MSU as far away as possible.

### 3. Connect and Power Up the MSU, Your PC, and the IntelliFile II

- a. Connect the IntelliFile II utilizing the supplied DB 9 Female to DB 9 Male connector cable. An adapter is supplied for those computers with serial ports configured with a 25 pin male connector (DB 25).
- b. Connect the IntelliControl to the IntelliFile II's PC Interface using the supplied 3-conductor transfer cable.
- c. Power up the IntelliFile II PC Interface and the IntelliControl MSU using their supplied 12V DC wall adapters. Follow the instructions provided with the IntelliFile II to enable you to connect and configure the PC Interface to your computer.
- d. Choose the labels from the label sheet and place them on the appropriate keys. Video sources should be assigned to the Master Keys on the left, audio sources on the right side of the remote. Snap the label protectors (enclosed with the unit) onto the keys, by

hand. If you wish to change an installed label, use a knife to gently pry the label protector off the key.

- e. To operate multiple IntelliControls within one house, you must change the “Unit ID” setting. The Tabletop Remote transmits a “Unit ID” with each RF command. There are 16 possible “Unit ID” settings which are configured via DIP switches inside the battery compartment of the Tabletop Remote. This enables up to 16 systems to simultaneously operate within a 100ft radius on the same transmitting frequency. *Note: The DIP switch settings inside the Tabletop Remote must match the “Unit ID” settings as configured on the “Utilities” tab in the IntelliFile II software.*
- f. Insert 3 “D” size alkaline batteries (not included) into the remote control. Be sure to maintain polarity.

#### **4. Install the Antenna**

- a. Insert the antenna BNC onto the antenna connector located on the Intellicontrol MSU and twist in a clockwise motion to tighten.

*Note: The antenna must be installed perpendicular to the ground in order to optimize reception. If necessary, use the supplied 90-degree elbow to ensure proper antenna alignment.*

- b. If physical limitations or interference issues prohibit the installation of the antenna directly to the MSU use the supplied 6-meter extension cable and mounting bracket to remotely install the antenna.

#### **5. Testing and Troubleshooting RF Transmission and Reception**

- a. Activate the Tabletop Remote by pressing a Master Key. *Note: One of the Master Keys must be selected (and lit) before a radio transmission will occur when a Function Key is pressed.*
- b. Observe the RF test LED while tapping “Channel Up” (or any Function Key) approximately once per second while moving the remote throughout the room. Try the antenna in various concealed locations, testing for the best range and accuracy by watching the RF Test LED as you operate the remote. You may need to try reposition the antenna to get good results in every location.

*A Flash of the Green LED = Indicates that the radio transmission has been received and understood. Move the remote to a new location within the room and retest until the remote operates properly in any potential end-use location.*

*A Flash of the Red LED = Indicates that interference was received or the button was tapped too rapidly. Press the “Channel Up” key no faster than once per second when testing. If the red LED lights frequently (or intermittently), move the antenna to another position and retest. No LED lights = Indicates that the RF signals are not being transmitted from the remote or received by the MSU.*

*Note: If you are experiencing RF interference (or no RF operation at all), remove the antenna and place the tabletop remote 1/2" away from the antenna socket. If the Green LED now lights when the "Channel Up" key is pressed (while a Master Key is selected), the RF circuitry is working, but the antenna is picking up excessive interference. Attempt to move the antenna.*

*If the red LED lights only when buttons are pressed (without the antenna connected), you may have the "Unit ID" code set incorrectly. Make sure that the DIPswitch settings inside the Tabletop Remote match those settings on the "Utilities" tab in the IntelliFile II software.*

*If the LED locks up red when the antenna is connected, the antenna is being "jammed" with continuous interference. Eliminate the source of the interference or relocate the antenna.*

## **6. Connect Flashers and Sync Cables**

Connect all flashers and sync connectors to the correct location on the Main System Unit (MSU).

- a. Label all cables for both the component they are connected to, and whether they are IR, sync, interconnect, or power. For example, the flasher routed to the TV is labeled "TV IR", while the sync cable from a 12V wall adapter plugged into the switched outlet of a Cable TV Decoder is labeled "CATV-Sync" (see Figure 12).
- b. Attach the flashers to the front panel sensors of each component, and plug each of the flasher plugs into the correct IntelliControl flasher connector that corresponds to that component's Master Key on the Tabletop Remote.
- c. Connect the 12V and video sync cables to the appropriate jacks for all respective source components.

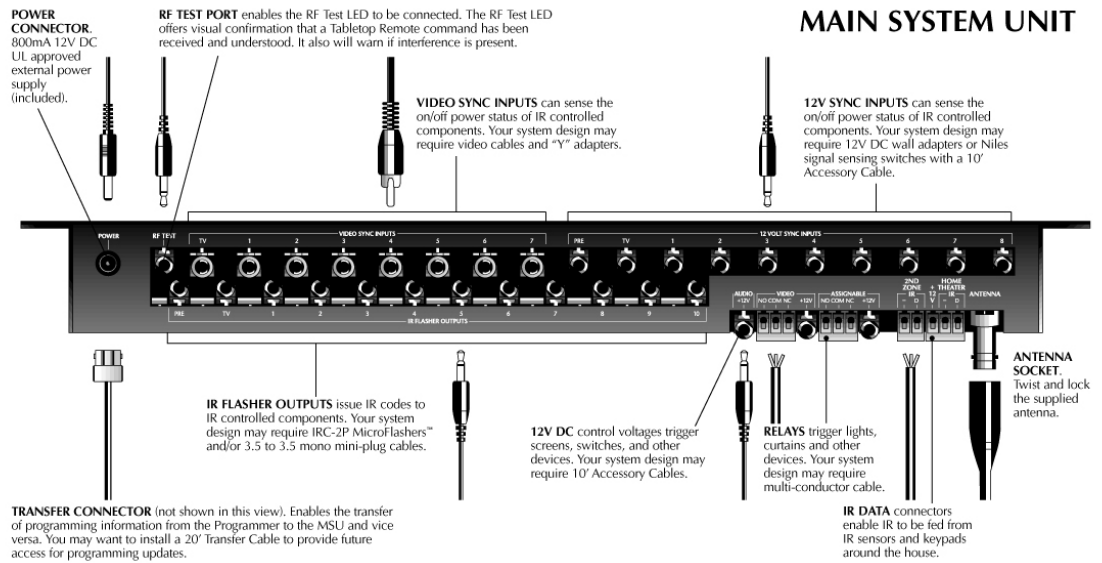

Figure 12 Labeling Cables

## 7. Flasher Level Check

Your flasher levels should be tested and adjusted using an Niles IR Sensor connected to the IntelliControl's "Home Theater IR" port before programming begins.

Note: Test each flasher and its level one at a time, with all other flashers unplugged. Connect the IR sensor and position it so that the component only receives IR commands via the sensor (and not from the remote directly!). Adjust the flasher level until proper operation occurs. If you have problems:

- Test only one flasher at a time. The IR output from another flasher might make any level adjustments you make faulty.
- The sensor must be positioned so that an IR command can only reach the component being tested via the flasher. Test this by disconnecting the sensor and directing the remote control at the unplugged sensor. If the component still operates, move the sensor to another location. If the component does not operate, connect the sensor and verify that the flasher level is correct by issuing a continuous code (volume down, scan etc.). Adjust the level until the component operates, as it should.
- The "TV" and "Flasher output #1" ports have twice the normal output level. When the flasher is adjusted to full output position an IRC-1 Flooding Flasher can control a rear projection TV with its IR sensor located behind the screen rather than on the front panel. *Note: When using projection televisions with the IR sensor located behind the screen, best results will be achieved by opening up the TV and mounting an IRC-2 Microflasher to the IR sensor inside the TV.*

## 8. The IR/RF Test LED

The RF test LED may be plugged into an IR flasher output to determine if the jack (or the flasher driver circuitry) is working properly. The Test LED should light red when commands are issued from the remote and output via that port. The Test LED may also be plugged into the jack on the bottom lip of the Tabletop Remote to determine if the tactile buttons are making contact.

*Note: Testing the Tabletop Remote with the Test LED DOES NOT determine if the Remote is transmitting RF, only that the buttons are making electrical contact.*

*Also Note: DO NOT PLUG THE TEST LED INTO THE AUDIO, VIDEO, OR ASSIGNABLE 12V CONTROL VOLTAGE OUTPUTS. YOU WILL DESTROY THE TEST LED.*

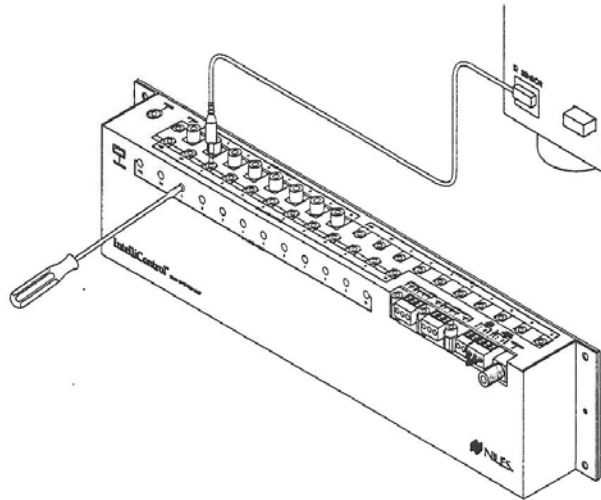

**Figure 13** Adjusting Flasher Levels

## Specifications

### The IntelliControl Tabletop Remote

*RF Carrier Frequency:* 418 MHz  
*RF Range:* Up to 100 feet  
*Backlighting Battery Life:* 60 hours continuously lit  
*RF Command Battery Life:* 100,000 commands  
*Batteries:* 3 "D" size batteries (not included)  
*Overall Dimensions:* 7" wide x 5" high x 4" deep  
*Weight:* 10 oz. without batteries, 1 lb. 9 oz. with three "D" batteries

### The IntelliControl Main System Unit

*IR Bandwidth:* 20kHz to 150kHz and 455kHz  
*IR Code Memory:* Over 1200 depending on brand or model of remote being learned.  
*Sequence Capability:* 312 twenty-six-step sequences  
*Sequence Delays:* .5 to 99 seconds  
*Contact & Control:* Assignable - N.O. / N.C. & 12V (momentary or latching)  
Video Scene - N.O. / N.C. & 12V (latching only)  
Audio Scene - 12V (latching only)  
*Mounting:* Wall-mount or Rack-mount  
*Wall-mount Dimensions:* 17" wide x 3-1/2" high x 2" deep  
*Rack-mount Dimensions:* 19" wide x 5-1/4" high x 3" deep (with optional rack-mount accessory)  
*Weight:* 4 lbs. 8 oz.

---

©2002 Niles Audio Corporation. All rights reserved. Because Niles continuously strives to improve its products, Niles reserves the right to change product specifications without notice. Niles and the Niles logo are registered trademarks of Niles Audio Corporation. Blending High Fidelity and Architecture, IntelliControl, IntelliPad, IntelliFile II, and MicroFlasher are trademarks of Niles Audio Corporation. 7/2000