

M O D E L S

DS6.3

DIRECTED SOUNDFIELD

DS6.5

DIRECTED SOUNDFIELD

DS6.7

DIRECTED SOUNDFIELD



Congratulations!

Thank you for choosing a Directed Soundfield Ceiling Mount Loudspeaker from Niles. With proper installation and operation, you'll enjoy years of trouble-free use.

Niles manufactures the industry's most complete line of custom installation components and accessories for audio/video systems. For a free full line catalog write: **Niles, Catalog Request, P.O. Box 160818, Miami, Florida 33116-0818**

TABLE OF CONTENTS

INTRODUCTION	2
FEATURES AND BENEFITS	2
INSTALLATION CONSIDERATIONS	4
SPEAKER PLACEMENT	6
INSTALLATION FUNDAMENTALS	9
INSTALLATION IN NEW CONSTRUCTION	13
INSTALLATION IN EXISTING CONSTRUCTION	14
FINAL INSTALLATION IN NEW OR EXISTING CONSTRUCTION	15
OPERATION	17
SPECIFICATIONS	18
WARRANTY REGISTRATION CARD	21
LIMITED WARRANTY	22



Introduction

Niles new DS Directed Soundfield loudspeakers feature a patented, fully adjustable, independently pivoting, woofer and tweeter that enables the loudspeakers to accurately recreate high fidelity sound regardless of where they

are located in the ceiling — preserving interior design integrity and delivering life-like sonic quality that is not available from conventional ceiling speakers.

Features and Benefits

Fully pivoting woofer and tweeter

A pivoting woofer assembly can adjust up to 15° focusing bass and midrange tones directly at the listening area for superb imaging and unparalleled clarity. Within the woofer assembly, the tweeter is housed in its own low-diffraction pivoting assembly that can adjust up to 17° in any direction to create direct or diffused sound fields. The independently pivoting woofer's and tweeter's superior design is patented, (U.S. patent number 6,683,963).

Moisture and UV Resistant Construction

The DS6.3, DS6.5 and DS6.7 loudspeakers are suitable for use in high moisture environments. The drivers are resistant to moisture and UV exposure; the grille is made of powder-coated aluminum. However, the speakers are not waterproof and direct contact with water should be avoided.

Engineered for Ceiling Placement

The increased popularity of cathedral and vaulted ceilings pose a distinct sonic challenge for conventional ceiling loudspeakers. That is because conventional ceiling speakers radiate sound perpendicular to their mounting surface, which usually is not where the listening area is. DS Directed Soundfield Loudspeakers patented, independent pivoting woofer and tweeter overcome this challenge and allow sound to be

directed into the listening area regardless of ceiling angle.

Installer Selectable Acoustic Fine Tuning

Installers can select to fine tune the bass or treble to accommodate reflective surfaces and corner loading. This selection is accomplished via the baffle-mounted treble control (-1.5dB, flat and +1.5dB) and PC board mounted bass jumper (flat, -1dB, and -2dB).

4 or 8 ohm Selectable Impedance

The DS6.3, DS6.5 and DS6.7 give the installer flexibility to select the speaker's impedance — 4 ohms for systems where maximum current transfer and output level is desired; 8 ohms for systems utilizing multiple speaker pairs where amplifier loading is a consideration.

MicroPerf™ Grilles

The DS6.3, DS6.5 and DS6.7 employ Niles exclusive MicroPerf grille construction. The exceptionally tight hole pattern provides acoustic transparency at all audio frequencies and enables the speaker elements to remain invisible. MicroPerf grilles can also be painted to blend seamlessly with the surrounding decor.

Easy Installation

The DS6.3, DS6.5 and DS6.7 employ a bracketless mounting system in existing ceilings. Simply cut a hole in the mounting surface, install the frame by tighten the four mounting “dogs” via the front panel screws. The dogs first swivel 90°, then clamp the speaker frame to the drywall as you tighten the screws.

Twist & Lock Baffle

Patented, (U.S. patent number 6,683,963) two-piece twist and lock baffle frame mechanism facilitates quick installations. Moreover, it allows trouble-free upgrades or repairs.

Hole Saving Bracket

Available as an optional accessory, DS6 Series New Construction Brackets can be installed as a “hole-saver” before the drywall goes up. The drywall contractor cuts the holes as the drywall is installed, reducing installation time and minimizing the chance for lost wires.

Installation Considerations

Recommended Amplifier Power

For satisfactory performance, we recommend an amplifier with a power rating of 10 to 100 watts for the DS6.3; 10 to 150 watts for the DS6.5 and the DS6.7. Curiously, most speakers are not damaged by large amplifiers but by small amplifiers. If your system is playing loudly, a small

amplifier will run out of power very quickly. When an amplifier runs out of power it creates damaging “clipping” distortion. A large amplifier will play at the same volume without distorting. See the section on operating the speakers for more information about clipping distortion.

Figure 1

The illustration shows how a typical DS loudspeaker mounts into a ceiling.

New Construction Bracket serves as a “hole saver” when drywall has not been applied. It is not necessary when retrofitting to existing ceilings.

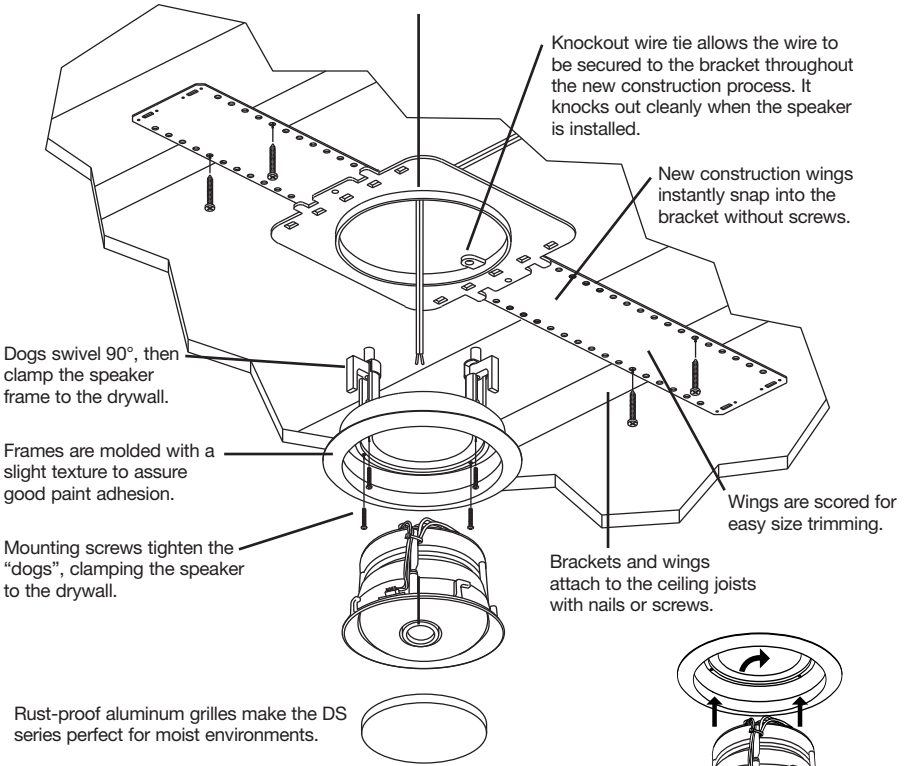
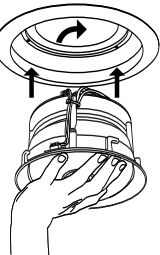

Figure 2 Connect the wires and place the speaker in the frame, twist and lock.



Incorporating a Local Volume Control

In a multiroom system there is one indispensable device for true convenience—a local volume control. It enables you to adjust the volume of the speakers without leaving the room.

Plan to wire the system so that each pair of speakers has its own volume control built into the wall (think of a volume control as a dimmer switch for sound).

Niles makes a wide range of high performance indoor and outdoor volume controls. They are available in Standard or Decora® style cover plates (just like your light switches and dimmers). Volume controls are connected in line with the speaker, so you must connect the wire from the amplifier to the volume control and then from the volume control to the speaker.

Speaker Wire

Use 2-conductor speaker wire when connecting DS6.3, DS6.5 and DS6.7 speakers to your receiver or amplifier. For most applications, we recommend you use 16 or 18 gauge stranded wire. For wiring runs longer than 80 feet we recommend 14 gauge stranded wire. The no-strip terminals of the DS speakers will accommodate 12 to 18 gauge wire.

When you run wire inside walls, special jacketing (CL-2 or CL-3) is required to both protect the wire and for fire prevention. In some areas conduit is required. For a trouble-free installation, low voltage wire such as speaker wire must be run in accordance with the National Electrical Code and any applicable provisions of the local building code. If you are unsure of the correct installation techniques, wire jacket or type of conduit to use, consult a

professional audio/video installer, your building contractor, or the local building and inspection department.

Incorporating Remote Control

If your stereo system operates with a wireless Infrared (IR) remote control, consider the advantages of installing a Niles Infrared Extender System. Niles manufactures a number of concealable IR sensors and wall mounted keypads which send a copy of your hand-held remote command via a wire to your main equipment location, where it is repeated to your stereo system. The wire is typically installed with the speaker wire, since the speaker signal and the IR signal will not interfere with each other. This makes almost no difference to the installation time, and the cost of the recommended IR control cable (West Penn D291 or equivalent) is reasonable.

The correct routing for IR control cable is to home run an IR control cable from the main equipment location beside the speaker wire to the planned volume control location; and then on to the proposed sensor location. The combination of IR control cable and speaker wire enables a programmable Niles IntelliPad® to be installed at a later date (the IntelliPad has a convenient speaker mute feature in addition to automating and controlling your stereo system). An IR sensor is best placed where it is convenient for you to point the hand-held remote. Both an IntelliPad and an IR sensor can be connected in one room with one home run IR control cable.

Insulation Behind The Speaker

For best performance from your speakers lay a batten of fiberglass insulation (example: R-19 un-batted insulation) on top of the speaker. Try to keep the same amount of insulation for each speaker, particularly in the same room, for consistent bass response.

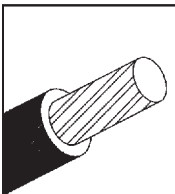

TECH TIP

Wire size is expressed by its AWG (American Wire Gauge) number. The lower the number, the larger the wire, i.e. 12 AWG is physically larger than 14 AWG.

Speaker Placement

Introduction

Although the DS6.3, DS6.5 and DS6.7 have extensive ability to compensate for unusual placements with their unique pivoting woofers, tweeters and acoustic fine-tuning switches, placement is still the primary tool for satisfying your particular listening needs. In this section, we discuss how speakers should be placed and how woofers and tweeters should be directed and how the acoustic fine-tuning switches should be set for different purposes.

Placement for Critical Listening

If you like to imagine that the band or orchestra is playing in front of you as you listen to music, or you are very conscious of clarity, detail and the textures of the individual instruments, or you listen critically to movie soundtracks or music videos in your home theater, you will need your speakers placed so that they are optimized for critical listening. Here are some guidelines to make the process of placement quick and easy.

Make sure the sound will not be blocked or reflected off of furniture or other objects. You should have a direct line of sight with the front of the speaker. To determine the best position, measure the “listening” distance between the ideal listening position (your favorite chair or couch) and the location in which you plan to install the speakers. Try to place the speakers so that they are equally distant from your listening spot and at least one half of the listening distance apart (this maintains a large pleasant stereo “image”). In home theater applications where there is a center channel you may choose to space the left and right main speakers farther apart for a “bigger than life” sound with Dolby® encoded movies and TV shows. However, for combined music and movie usage stay within the *good placement zone* for music. For example; if you are ten feet back from the speakers, the speakers should be between five and ten feet apart (**See Figure 4**).

Woofers and tweeters should be directed at the listening position.

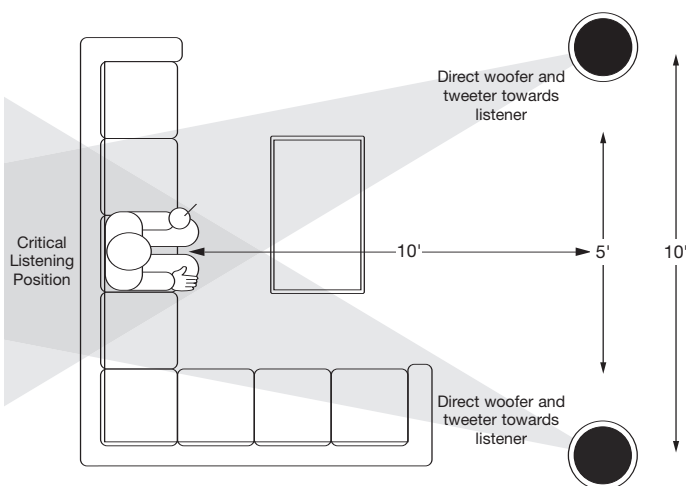

Figure 4

In this example, the speakers could be placed from five to 10 feet apart, since the listener is 10 feet back from the speakers

Placement for Varying Listening Positions

If you want the freedom to sit anywhere in a room facing any direction, and/or find that you prefer the “all around you” sound of some car stereos to a conventional “sound stage” facing you, consider the speaker placement techniques professional installers use in restaurants and bars. They place speakers in an array around the listening area, so that the music is always surrounding you, regardless of the direction you face.

The rule of thumb is to add one pair of speakers for every 100 to 200 square feet of listening area. Curiously, this is not so that you can play the music louder, but so that you can play it softer! When you have only one pair of speakers in a large room you will notice that when the sound is perfect in one part of the room, it is too loud near the speakers. By placing more than one pair in the room you will avoid these “hot spots” of loud sound and you will create more sonic ambiance while maintaining clarity and a rich sound everywhere (See Figure 5).

You can make listener position still less critical by using mono rather than stereo. This can be difficult to achieve with normal stereo amplifiers. However, Niles manufactures Systems Integration Amplifiers® which enable one room to be wired in stereo while other rooms are wired in mono! Consult your local Niles dealer for more information.

In smaller rooms or rooms that are infrequently used, you typically can't justify the expense of more than two speakers. Try to bracket the room with the two speakers. Diagonal placement is a very effective way to stretch the coverage pattern of two speakers. You can also compromise between direct sound (for detail and clarity) and reflected sound (the ambient or “all

around you” effect). The speakers can be placed near corners to create more reflected sound. By directing the tweeters to point away from the listener, so they create as much reflected sound as possible, you emphasize the ambient effect. The more reflected sound there is in the room the stronger the ambient effect at low volumes. You should use moderation, however, otherwise the compromise becomes too one sided and at high volumes, the sound will be blurred and less distinct.

Placement for Home Theater Rear Applications

In a home theater, the goal is to reproduce the experience of a great movie theater in our homes. The biggest difference between the two is the rear or surround speaker array in a commercial theater. Here, it is not uncommon to see twenty or thirty speakers around the audience. This huge array of speakers assures that you will feel completely surrounded by the ambient soundtrack of the movie. Film makers try to use the “surround” soundtrack to envelope you in the environment on screen. They will place background music, rain sounds, traffic noise, etc. on the “surround” soundtrack. In a home with a single pair of speakers it is easy for the jungle sounds to sound like they are “in the middle of your head” just like headphones!

A single pair of DS6.3, DS6.5 and DS6.7 Loudspeakers, properly placed, can create a very convincing simulation of an array of speakers. If you place them near a hard reflecting surface you can make one pair of speakers sound like several. Create as many reflections as possible by placing the speakers near a corner so that the adjoining walls will act as a powerful reflector. Direct the tweeters so that sound is pointed away from the listener creating still more reflections and thus more “surround sound” effect. However, as you

move the speaker farther away from the listener, both the reflected and the direct sound will dissipate, requiring more power from your surround sound amplifier channels. If the surround sound system you are using has a small five or ten watt amplifier for the rear speakers, stay within five to eight feet of the listening location. If you are using a 25 to 50 watt amplifier you can mount the speakers 10 to 15 feet away from the listening location and still achieve reasonably high volume levels.

In large or unusually shaped rooms this might be the only way to achieve a good effect. If you like to listen to music surround modes which emulate concert hall acoustics, more than two surround speakers will prove extraordinarily effective (See **Figure 6**). With Niles DS6.3, DS6.5 and DS6.7 loudspeakers it is easy to add another pair without affecting the decor of the room. However, you will need to use a much more powerful amplifier than that which is built into a typical surround sound receiver or amplifier. Niles makes a number of Systems Integration Amplifiers with proprietary features that make them

uniquely suited to enhance a good surround sound system. Consult your local Niles dealer for more information.

The Boundary Effect

Corners can affect the bass response of the speaker powerfully! This is called the boundary effect. You will emphasize particular bass frequencies and cancel out other bass frequencies when you place speakers close to the wall/ceiling boundary or a corner wall boundary. This can make the speaker sound excessively boomy and inaccurate to some listeners, while to others it just seems like more bass sound. A good rule of thumb is if you always listen to your current pair of speakers with the bass turned up, you'll enjoy corner placement. If you keep your tone controls at neutral, try to keep the speakers at least two or three feet from the boundaries of the room.

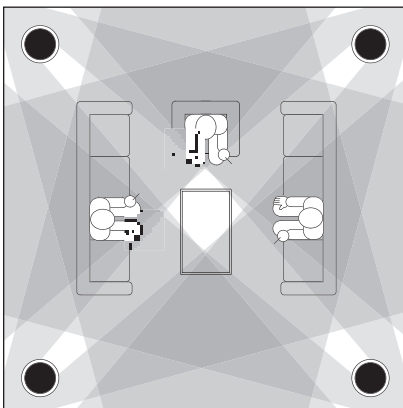

Figure 5
Varying Listening Position

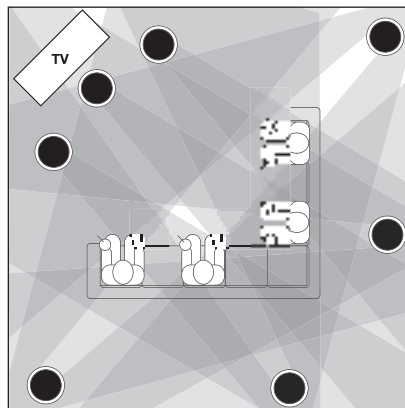

Figure 6
Surround Sound

Installation Fundamentals

Running the Speaker Wire in New Construction

If you have doubts about whether you are capable of installing a Niles ceiling mount loudspeakers, consult a Niles dealer or professional installer. They have special tools, techniques, and experience to make the impossible possible. The installer can provide you with an estimate before any work is done.

Scheduling and Preparation

Plan to schedule the speaker wiring after the electrical wiring is finished. That way you can avoid wire routes which could potentially induce hum over the speaker wire. The basic rules are:

- Never run speaker wire through the same hole as an electrical cable.
- Never run speaker wire into the same J-box as electrical cable.
- Avoid running the speaker wire beside the electrical cable. Keep your speaker cable at a distance of at least 18"-22" from any electrical power cable.

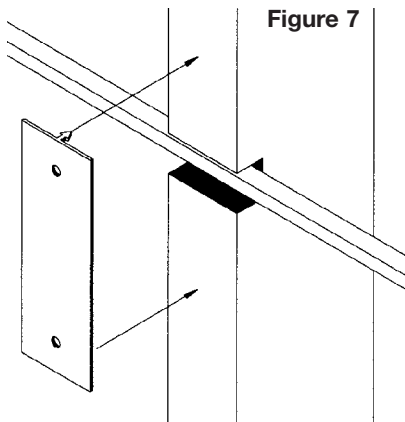

Figure 7

Side-by-side wiring is unavoidable in particular spots in every house, just move the speaker wire route away as soon as possible. If construction forces a side by side run for more than ten feet, install metal conduit or shielded speaker wire. Low-voltage wires such as doorbells, intercoms, telephone, security, or television cannot cause interference or hum on your speaker wires, so you can safely run all of them at the same time, through the same holes, side-by-side.

Before you drill any holes, mount the speaker brackets in the desired speaker locations and mount p-rings or open backed J-boxes where the in-wall volume controls and stereo equipment will be.

Safety First!

Wear gloves, safety goggles and head protection when drilling. Avoid nails, they ruin bits and they can create injury. Pay particular care when using "hole-hogs" and other powerful electric drills; the torque of the drill when suddenly stopped by a nail can break the wrist of a strong man.

Drilling

Use a bit that is large enough for the wires you plan to run. An auger bit is the preferred bit for rough-in wiring. It will actually pull itself through the wood, so that the drill motor, not you, does most of the work. You may be drilling a lot of holes, so this is an important consideration.

Always drill the holes in the center of the stud. If you have to notch the stud or drill the hole closer than one inch from the edge of the stud, protect the wire with a nail plate (**See Figure 7**).

When drilling holes in ceiling joists drill in the center of the joists and try to locate the hole near the end of the joist. **DO NOT** drill through a "gluelam" or any load bearing beam without the direction of your contractor.

Try to line the holes up perfectly, because it makes pulling the wire much easier. A good technique is to snap a chalk line across the face of the studs or against the bottom of the ceiling joists. Then work backward so that you can always see the holes you have already drilled. Paying careful attention to this will save you a lot of time later on!

Pulling the Cable

Pull the cable in sections (from the stereo to the volume control, from the volume control to the speaker). Start with the longest sections and use left over wire to complete the short sections. If you plan to pull many rooms at the same time through a central route, walk off the distance to each destination, add a generous fudge factor for turns and other obstacles, then cut off each section so that you have a bundle of wires you can pull at once.

Whenever you run the wire further than four and one half feet from a hole in a stud or joist (open attic space, going up walls, etc.), fasten the wire to the joists or studs using cable clamps or appropriately sized wire staples. The wire should not have large sags in it, nor should it be too tight. Try to protect the wire from being stepped on in attics or other unfinished crawl spaces. There are guard strips, raceways and conduits which can be used to protect the cable. Consult the local building code for special requirements in your area.

Concealing Speaker Wire in Existing Walls

This is actually a fairly simple task if you restrict your choice of speaker locations and wire routes to the interior walls or ceilings of your home. Interior walls in almost all North American residences are hollow, so that it is easy to flush mount speakers into them and route new speaker cable around the house. What you see

when you look at the painted wall board, plaster, or paneling is only the skin of the wall. Behind the skin is the skeleton; two-by-four wood or metal “studs” running vertically from the floor to the ceiling in walls and two-by-six or larger “joists” running horizontally in the ceilings and floors. In between the studs and the joists is the space for the wiring and plumbing of your home.

Exterior walls are different. They must insulate the house from the heat and cold outside, so they are stuffed with insulation. The national building code requires that the hollow wall space in exterior walls be broken by a horizontal stud placed between the vertical studs. This “fire blocking” makes it very difficult to retrofit long lengths of wire. In some areas of the country the exterior walls are constructed of solid masonry, and have no hollow space for speakers or wires.

Start by examining all the possible routes you might take to run the speaker wire from the speaker to the volume control and back to the stereo. Use a stud sensor or other device to locate the internal structure of the wall. You want to avoid all studs or joists. A typical route would be: from the speaker location in the ceiling, across the attic, then down through a top plate (the horizontal 2x4 or 2x6 laid across the vertical studs) to the volume control location, back up to the attic, across the attic, and finally down another wall plate to a J-Box in the wall behind the stereo system itself (**See Figure 8**).

Identify where all of your electrical, phone, and TV wiring is likely to be and plan to route around it all. You can accidentally induce 60Hz hum on your speakers if you run your speaker wire right beside electrical wire for more than a few feet. Try to keep speaker wire running par-

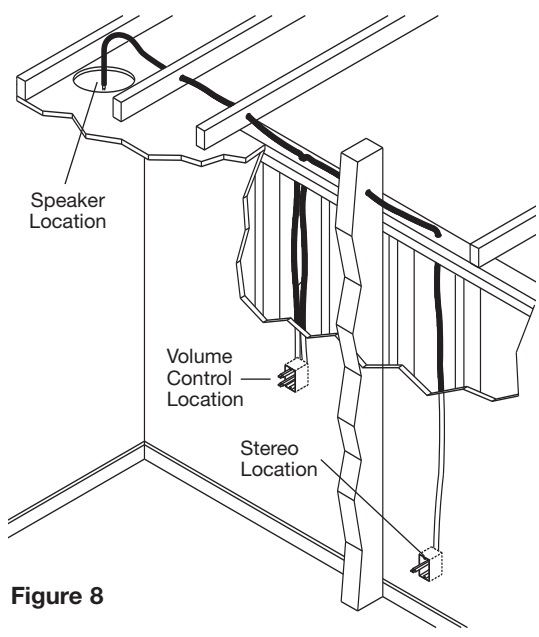

Figure 8

allel to power cables at least three feet away. To find exactly where an electrical cable is routed, try inspecting the inside of the wall by turning off the breaker for a particular power outlet or switch, removing the cover plate and switch or receptacle, and shining a penlight into the wall. If you have access to an attic or basement space you can quickly see which part of the wall space is free of obstructions (See Figure 9).

When you don't have access above or

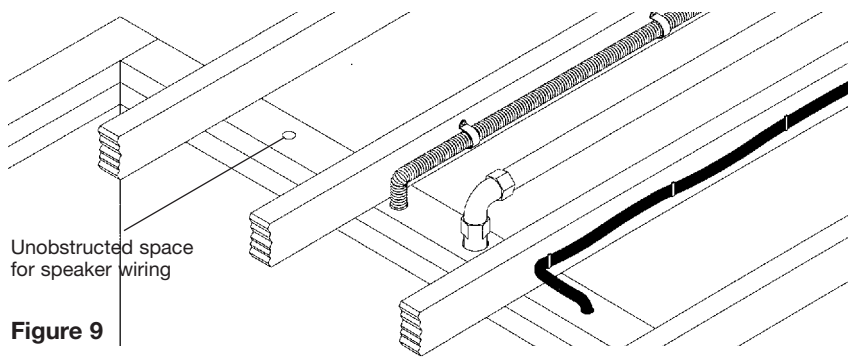

Figure 9

below the wall, try to estimate the existing wire and pipe locations from the positions of electrical outlets and plumbed fixtures on both sides of the wall. Take a look at the outside of your house too, sometimes conduit, vents or drain pipe will be visible that give useful information. Choose the route with the fewest potential obstacles.

If your house is built on a slab or you are wiring between two finished floors, look for baseboards which could be removed and replaced with the wire behind them. Doorjamb can be removed and often have enough space for speaker

wire all the way around the door (See Figure 10).

Sometimes, an under-the-carpet run is possible (there are special flat speaker wires made for under-the-rug wire runs). As a last resort, heating and air conditioning vents can be used as wire raceways for plenum rated wire (check your local building codes, some municipalities require conduit).

In traditional wood stud/drywall construction you should first cut the hole for the speaker and utilize the large hole to auger across the (through the ceiling joists) for as far as your drill bit will take you. Sometimes, you will need to use the “notching” technique to reach areas your drill bit won’t reach or to turn corners (e.g. to go down the wall when there is not an accessible attic). Don’t make an irregular hole in the drywall. If you carefully cut a rectangular hatch in the drywall you will make your patch at the same time you cut your hole. Notch the bottom of the joists and run the wire through the notches. Protect the wire with nail plates. Once you’ve run your wire replace the hatch you cut using standard drywall “joint tape” and “joint compound” to hold the patch in place, let dry, sand surface and touch-up the wall with paint. (See Figure 11).

Figure 10

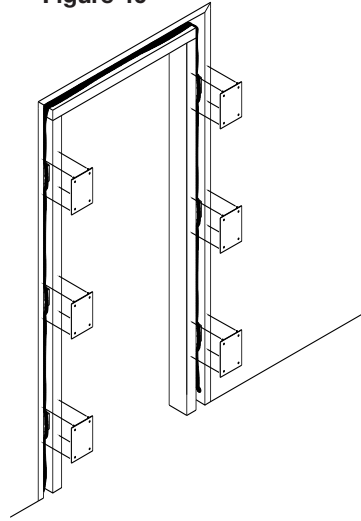

The door jamb has been removed and the speaker wire concealed between the wall and the jamb. Nail plates are installed to protect the wire and the door jamb is replaced

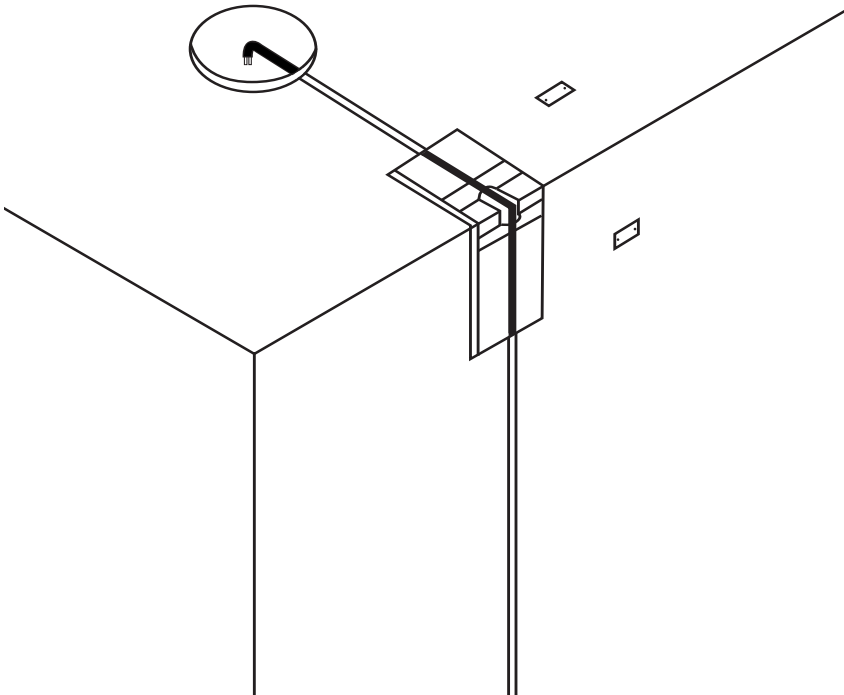

Figure 11 Diagram of ceiling speaker cut-out with ceiling joists notched for wire run.

Installation in New Construction

Insulating the Ceiling Cavity

If feasible, fill the ceiling cavity with insulation at this point.

Mounting the New Construction Bracket

The hole saving bracket enables a faster and cleaner final installation of the speaker. It forces the drywall installer to cut out the speaker hole for you and provides wire ties for the speaker wire, reducing the risks of accidental loss or movement of the wire. In addition, it enables you to align your speakers with other ceiling fixtures with great accuracy since you can really see exactly where the speaker will be.

To install the bracket, first attach the QuickSnap™ new construction wings to the bracket by snapping them into the sides of the bracket. The wings can be shortened by breaking them along the scored lines if the length will interfere with corner or eaves.

The wings and brackets have centering lines to simplify placement of the speakers.

Screw one side of the assembled bracket with wings to the joist using one of the supplied screws. Level the bracket. Screw the other side of the bracket/wing assembly to the joist. Two screws on each side make for a very secure installation. Secure the wire to the bracket using bracket's wire tie. The drywall installers will cut the drywall to the exact size of the bracket. **(See Figure 12)**

Concealing Speaker Wire for a Future Installation

Attach the speaker wire in a loop between the ceiling joists and carefully mark the exact location of the wire on a set of plans. Ask the general contractor to inform the drywall installers that the speaker wire loops are concealed for future installations. **(See Figure 13)**

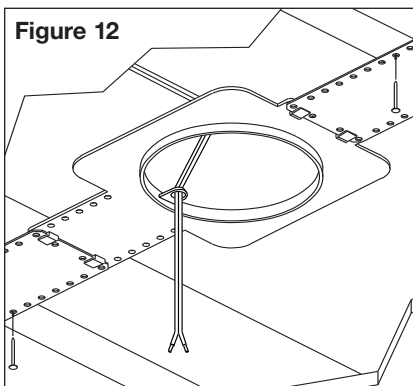

Figure 12
The optional hole saving brackets are installed and the speaker wire is attached to the bracket.

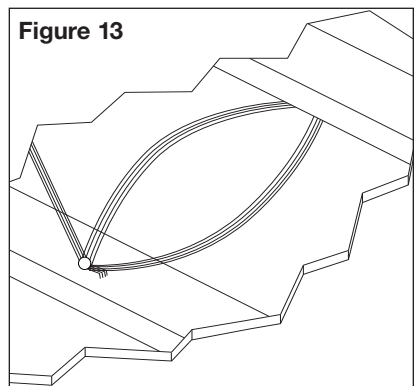

Figure 13
The speaker wire is looped and hung on two nails attached to the joists securing it for future use. Make sure the location is noted on house plans.

Installation in Existing Construction

IMPORTANT: Before you cut into any wall, review the sections on running wire and speaker placement.

1. When determining the location of the speaker cutout keep in mind that the mounting dogs will extend 3/4" beyond the cutout. make sure that you do not place the edge of the cutout directly next to a ceiling joist. Locate the joists using a stud sensor or hand-knocking.
2. Once you have determined a possible position for the cutout, drill a 1/8" pilot hole just barely through the ceiling (1/2" to 5/8" deep in most homes) about an inch below the center of your proposed speaker location. BE VERY CAREFUL NOT TO DRILL THROUGH EXISTING WIRES, PIPES, OR STRUCTURE. IF YOU FEEL ANY EXTRA RESISTANCE AS YOU ARE DRILLING, STOP.
3. Cut a foot-long piece of coat hanger. Bend the wire (creating a right angle) leaving 4-3/4" this allows for the extra width of the mounting dogs). Poke the "L-shaped" wire into the pilot hole and turn it in a complete circle and move it into the ceiling cavity to make sure you have approximately 6" of depth. If the wires movement is obstructed by anything, fill the hole(s) with spackle and try another location. **(See Figure 14)**
4. If the coat hanger moves freely in a complete circle, hold the supplied template up to the ceiling surface. Outline the circular cutout on the ceiling surface with a pencil. Drill starting point with a 1/4" bit.

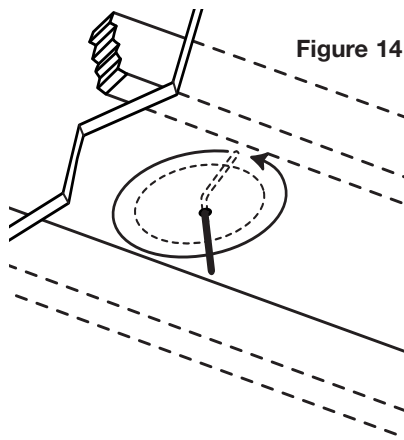

Figure 14

5. If you are cutting drywall use a sheetrock or keyhole saw. Cut the hole with the saw at a 45° angle. That way, the drywall section can be replaced cleanly if there is an unseen obstruction behind the wall. BE VERY CAREFUL NOT TO SAW THROUGH EXISTING WIRES, PIPES, OR STRUCTURE. IF YOU FEEL EXTRA RESISTANCE AS YOU ARE CUTTING, STOP.
6. If you are cutting into a plaster ceiling, use masking tape to outline your penciled circle and use a razor to score the plaster down to the lath beneath. Then use a chisel to remove all of the plaster within the taped outline. To actually cut the lathe, two methods are used professionally; sawing with a metal cutting blade on a sabre saw is the quickest and the *riskiest*. Sawing a lathe with a sabre saw can easily vibrate plaster off the ceiling in a completely distant location creating more patchwork. If you have the patience, use a pair of tin snips to slowly nip away at the lath instead. There is little risk with this method, it is just time consuming.

Final Installation in New or Existing Construction

1. If it is possible to lay a batt of insulation into the ceiling cavity do so. Remember to use equal amounts of insulation for each speaker.
2. Check the position of the Impedance jumper on the crossover PC board. Choose the 4 ohm position if you are using an amplifier capable of driving a 4 ohm load and you have only one pair of speakers connected. Otherwise, use the 8 ohm position **(See Figure 15)**.
3. The DS6.3, DS6.5 and DS6.7 feature a separate frame assembly which installs with four clamps or mounting "dogs" which hold the frame in place. The dogs are tightened via four front-baffle screws. Tighten the dogs by turning the screws clockwise. **DO NOT OVERTIGHTEN THESE SCREWS.** Over-tightening the clamps may make the grille difficult to install. **(See Figure 16)**.

NOTE: The screws will turn easier if you "prime" them first. Before installing each speaker, turn the screws in and then turn them back out to their original positions.

4. Separate the speaker end of the two-conductor speaker-wire run to free at least 2" of each conductor.

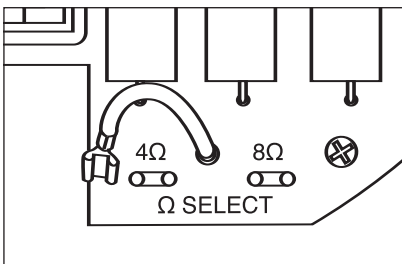

Figure 15 Setting the Impedance jumper.

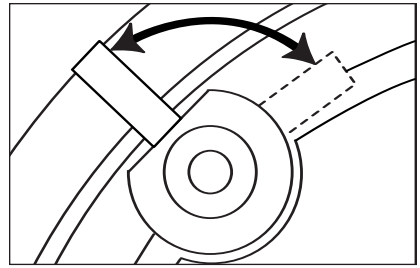

Figure 16 Tightening the mounting "dogs"

5. Strip 1/2" of insulation from the end of each conductor. **(See Figure 17.)**
6. To connect the stripped end of one conductor to the black terminal, push down on the black terminal lever. Insert the stripped end of the conductor into the opening. Release the pressure on the lever.
7. Repeat # 3 with the other conductor and the red terminal.
8. Connect the opposite ends of these conductors to their respective amplifier terminals. Pay attention to the markings on the wire. If you are unsure which conductor to insert into which terminal, see the section titled "Speaker Phase" in the owner's manual.
9. Repeat these instructions for each speaker you are connecting to the amplifier.
10. Holding the speaker in the palm of your hand, insert the speaker into the frame, twist clockwise to lock. **(See Figure 18)**.

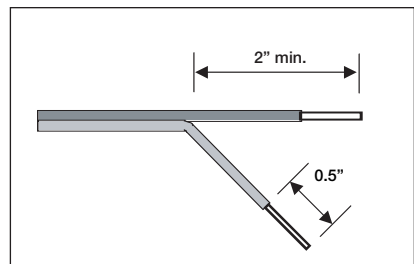

Figure 17 Wire Stripping Details.

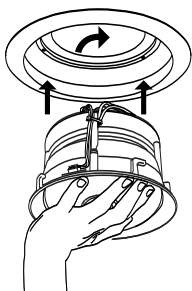

Figure 18
Installing the speaker

11. Direct the Tweeter. The tweeter is directed by gently pushing on the edge of the tweeter housing. (See Figure 19). It will move 17° in any direction. For critical listening point the tweeter to the user's favorite listening position minimizing reflections from the side walls. For surround sound or low volume background listening create more reflections and thus more ambience by directing the tweeter towards the side walls.

12. Direct the Woofer. The woofer is directed by gently pushing on the outer edge of the grille face. (See Figure 20). It will

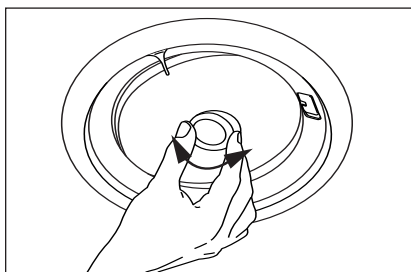

Figure 19 Directing the tweeter.

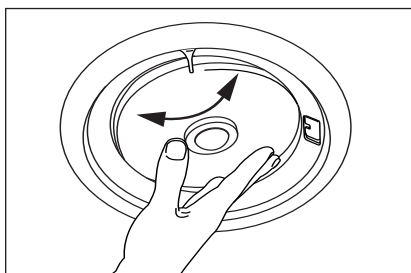

Figure 20 Directing the woofer.

move 15° in any direction. For critical listening point the woofer to the user's favorite listening position minimizing reflections from the side walls. For surround sound or low volume background listening create more reflections and thus more ambience by directing the woofer towards the side walls.

13. Setting the Treble cut switch. Listen to a well-recorded piece of music at the user's favorite listening position. Listen for treble harshness or ringing, particularly when the speakers are placed in a room without carpet. Use the +/-1.5dB Treble switch to correct.

14. Setting the bass jumper. Listen to a well-recorded piece of music at the user's favorite listening position. Listen for bass boominess, particularly when the speaker is placed near a corner. Remove the speaker by grasping the tabs and rotating counter-clockwise. Adjust the bass jumper (-1dB, -2dB) accordingly. (See Figure 21).

15. Install the grille into the speaker. The grilles should fit snugly. If you have difficulty fitting them in, try loosening the mounting dog screws (excessive tightening can distort the shape of the frame holding the grille in place).

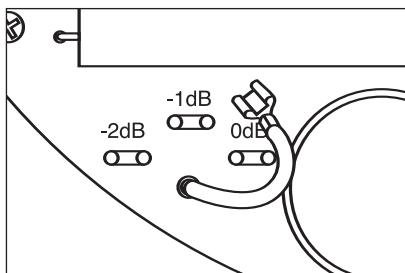

Figure 21 Setting the bass jumper.

Speaker Phase

Speaker wire has two conductors. One conductor is attached to the negative (-) terminals and one conductor is attached to the positive (+) terminals of both your speaker and your amplifier. Usually, the wire is marked for your convenience. There are different ways wires are marked: a stripe on one wire, a ribbed area of one conductor you can only feel, different colors of metal wire on each conductor, or there might be a fabric strand or string wound into one of the conductors. Of course, there are some wires which appear completely identical. Be careful, or you might make a mistake.

If you make a mistake, one speaker will be playing “out-of-phase” with the other speaker. An out-of-phase pair of speakers work against each other and the sound of the two speakers playing together will be lacking in bass and be “phasey” sounding. If you suspect the sound is not right and you cannot see any markings on the wire, try this simple test:

1. Stand half way between the speakers.
2. Play some music with the amplifier or radio set to Mono.
3. Listen to the richness of the bass and the loudness of the sound.
4. Turn off the amplifier and reverse the connections on one amplifier channel only.
5. Repeat the listening test with the same setting of the volume control. When the sound has a richer bass and is slightly louder the speakers are working together or “in-phase”.

Operation

Listening at Higher Volumes

It requires more power to achieve a reasonable volume of sound in a large room than it does in a small room. It is possible (even if you are not a teenager) to turn the volume so high that the amplifier *runs out of power*. This creates “clipping” distortion.

Clipping distortion makes treble sound very harsh and unmusical. When you hear harsh sounding treble from any good speaker, turn the volume down immediately! Those harsh sounds are masking some much more powerful ultra-high-frequency sound spikes which will quickly damage any fine loudspeaker. You are much less likely to damage a speaker with a large amplifier because it will be very loud indeed before it produces any clipping distortion.

Cleaning

You can clean the speaker with a dampened soft cloth or paper towel. If the speaker is mounted high up on a wall or ceiling, use a broom to gently brush it off.

Specifications

DS6.3

Driver Compliment

Injection molded polypropylene woofer with butyl rubber surround in an integrated patented pivoting mount, (15° pivot angle)

1" fluid-cooled ultra-wide dispersion silk dome tweeter in a patented low diffraction pivoting mount, (17° pivot angle)

Recommended Amplifier Power

10 to 100 watts per channel

Tone Controls

Bass jumper: flat, -1dB and -2dB
Baffle-mounted Treble controls:
-1.5dB, flat and +1.5dB

Nominal Impedance

4 or 8 ohm selectable

Frequency Response

50Hz to 20kHz, +/- 3dB (on axis)

Sensitivity

87.5dB for 2.83 volts of Pink Noise

Overall Exterior Frame Dimensions

9-7/8" diameter

Depth Behind Wall

6" deep (based on 1/2" drywall)

Hole Cut-Out Dimensions

8-5/8" diameter

Wiring Requirements

Dual Gold Push Terminals accommodates 12–18 gauge wire. We recommend 16–18 gauge stranded wire for up to 80 feet, 14 gauge stranded wire for up to 200 feet.

DS6.5

Driver Compliment

Injection molded graphite reinforced polypropylene woofer with butyl rubber surround in an integrated patented pivoting mount, (15° pivot angle)

1" fluid-cooled ultra-wide dispersion tri-laminate Teteron dome tweeter in a patented low diffraction pivoting mount, (17° pivot angle)

Recommended Amplifier Power

10 to 150 watts per channel

Tone Controls

Bass jumper: flat, -1dB and -2dB
Baffle-mounted Treble controls:
-1.5dB, flat and +1.5dB

Nominal Impedance

4 or 8 ohm selectable

Frequency Response

50Hz to 22kHz, +/- 3dB (on axis)

Sensitivity

88dB for 2.83 volts of Pink Noise

Overall Exterior Frame Dimensions

9-7/8" diameter

Depth Behind Wall

6" deep (based on 1/2" drywall)

Hole Cut-Out Dimensions

8-5/8" diameter

Wiring Requirements

Dual Gold Push Terminals accommodates 12–18 gauge wire. We recommend 16–18 gauge stranded wire for up to 80 feet, 14 gauge stranded wire for up to 200 feet.

Specifications

DS6.7

Driver Compliment

High Output injection molded graphite reinforced polypropylene woofer with shorting ring and butyl rubber surround in an integrated patented pivoting mount, (15° pivot angle)

1" fluid-cooled ultra-wide dispersion tri-laminate Teteron dome tweeter in a patented low diffraction pivoting mount, (17° pivot angle)

Recommended Amplifier Power

10 to 150 watts per channel

Tone Controls

Bass jumper: flat, -1dB and -2dB

Baffle-mounted Treble controls:

-1.5dB, flat and +1.5dB

Nominal Impedance

4 or 8 ohm selectable

Frequency Response

48Hz to 22kHz, +/- 3dB (on axis)

Sensitivity

89dB for 2.83 volts of Pink Noise

Overall Exterior Frame Dimensions

9-7/8" diameter

Depth Behind Wall

6" deep (based on 1/2" drywall)

Hole Cut-Out Dimensions

8-5/8" diameter

Wiring Requirements

Dual Gold Push Terminals accommodates 12–18 gauge wire. We recommend 16–18 gauge stranded wire for up to 80 feet, 14 gauge stranded wire for up to 200 feet drywall)

PLEASE FILL OUT THE
WARRANTY REGISTRATION
CARD ON THE REVERSE SIDE,
DETACH, AND MAIL TO:

Niles Audio Corporation
Warranty Registration Dept.
P.O. Box 160818
Miami, Florida 33116-0818

DETACH HERE



WARRANTY REGISTRATION CARD

Model Purchased _____

Serial Number _____

Date Purchased (month/day/year) _____

Dealer Name and Location _____

Dr. Miss Mr. Mrs. Ms.

Name _____

Address _____

City _____ State _____ Zip _____

Telephone (_____) _____

Please take a moment to fill out our warranty registration card. The information helps us to get to know you better and develop the products you want

Age:

- Under 25
- 25-34
- 35-44
- 45-54
- 55 & over

Income:

- Under \$24,999
- \$25,000-\$34,999
- \$35,000-\$44,999
- \$45,000-\$59,999
- \$60,000-\$74,999
- \$75,000-\$99,999
- Over \$99,999

Occupation:

- Arts/Entertainment
- Business Owner
- Engineer
- Finance/Accounting
- General Office
- Management
- Professional
- Sales/Marketing
- Student
- Tradesperson

Musical tastes:

(Please check all that apply)

- Alternative
- Classical
- Country
- Jazz
- New Age
- Popular
- R&B
- Rock
- Other _____

How did you hear about Niles?

- Architect/Developer
- Custom Installer
- Direct Mail
- Friend/Family
- In-Store Display
- Interior Designer
- Magazine Ad
- Mail-Order Catalog
- Newspaper Ad
- Product Brochure
- Product Review
- Retail Salesperson

What magazines do you read?

1. _____
2. _____
3. _____

Who will install the product?

- Custom Installer
- Electrician
- Friend
- Myself

Which factor(s) influenced the purchase of your Niles product?

(Please check all that apply)

- Ease of Use
- Price/Value
- Product Features
- Quality/Durability
- Reputation
- Style/Appearance
- Warranty

Do you . . . ?

Own a House. If yes, how many square feet? _____

Own a Town House/Condominium/Co-op

Rent an Apartment

Rent a House

Are you interested in receiving literature on other Niles products?

Yes No

Are there products/capabilities that you would like to see introduced?

Limited Warranty

Niles Audio Corporation ("NILES") warrants its loudspeaker products to the original purchaser to be free of manufacturing defects in material and workmanship for a period of five years from date of purchase.

This Warranty is subject to the following additional conditions and limitations. The Warranty is void and inapplicable if NILES deems that the product has been used or handled other than in accordance with the instructions provided by the manufacturer, including but not limited to damage caused by accident, mishandling, improper installation, abuse, negligence, or normal wear and tear, or any defect caused by repair to the product by anyone other than NILES or an authorized NILES dealer.

To obtain warranty service, take the unit to the nearest authorized NILES dealer, who will test the product and if necessary, forward it to NILES for service. If there are no authorized NILES dealers in your area, you must write to NILES and include your name, address, model and serial number of your unit, along with a brief description of the problem. A factory Return Authorization Number will be sent to you. **DO NOT RETURN ANY UNIT WITHOUT FIRST RECEIVING WRITTEN AUTHORIZATION AND SHIPPING INSTRUCTIONS FROM NILES.**

If the above conditions are met, the purchaser's sole remedy shall be to return the product to NILES, in which case NILES will repair or replace, at its sole option, the defective product without charge for parts or labor. NILES will return a unit repaired or replaced under warranty by shipping same by its usual shipping method from the factory (only) at its expense within the United States of America. **THERE ARE NO OTHER WARRANTIES, INCLUDING WITHOUT LIMITATION, EITHER EXPRESS OR IMPLIED WARRANTIES OF MERCHANTABILITY OR FITNESS FOR A PARTICULAR PURPOSE, WITH RESPECT TO THE PRODUCT.**

REPAIR OR REPLACEMENT AS PROVIDED UNDER THIS WARRANTY IS THE EXCLUSIVE REMEDY OF THE CONSUMER/PURCHASER. NILES SHALL NOT BE RESPONSIBLE FOR ANY INCIDENTAL OR CONSEQUENTIAL DAMAGES EXCEPT TO THE EXTENT PROVIDED (OR PROHIBITED) BY APPLICABLE LAW.

Some states do not allow the exclusion or limitation of incidental or consequential damages, so the above limitation may not apply to you. This warranty gives you specific legal rights, and you may also have other rights which vary from state to state.

For the name of your nearest authorized NILES dealer contact:

NILES AUDIO CORPORATION
P.O. BOX 160818, Miami, Florida 33116-0818.

Please fill in your product information and retain for your records.

Model _____

Serial No. _____

Purchase Date _____



NILES®

www.nilesaudio.com

**Niles Audio
Corporation**

12331 S.W. 130 Street
Miami, Florida 33186

Tel: (305) 238-4373

Fax: (305) 238-0185

Printed in Brazil



©2004 Niles Audio Corporation. All Rights Reserved. Niles, the Niles logo, and Blending High Fidelity and Architecture are registered trademarks of Niles Audio Corporation. All other trademarks are the property of their respective owners. Because we constantly strive to improve our products, Niles reserves the right to change product specifications without notice. The technical and other information contained herein is not intended to set forth all technical and other specifications of Niles products. Additional information can be obtained on-line. DS00295BBR