

INSTALLATION & OPERATION GUIDE



CS100

CEILING MOUNT INFRARED SENSOR



B L E N D I N G H I G H F I D E L I T Y A N D A R C H I T E C T U R E ®

CS100

Ceiling Mount
Infrared Sensor

TABLE OF CONTENTS

Introduction	1
Features and Benefits	2
Installation Considerations	3
Installation	7
Operation	8
Troubleshooting	8
Contents	10
Specifications	10



Introduction

The CS100 is a ceiling mounted IR sensor designed for use with the Niles infrared extender systems.

Installed in a remote room location, the CS100 receives the IR commands transmitted from your existing hand-held remotes in that room. The commands are carried via a category 5 cable to your A/V equipment in another room, and instantly “repeated”.

The CS100 is compatible with all current Niles infrared systems. It may be used along with, or as an alternative to, the Niles TS100, MS100, MS200, WS100 and MVC100IR sensors or the IntelliPad®.

The CS100 is just one part of the three building blocks necessary to complete a Niles IR repeating system

- IR Main System Unit—Models MSU140, MSU250, MSU480 and MSU440Z.
- IR Sensors/Keypads—Models WS100, TS100, MS100, MS200, CS100, MVC100R and the IntelliPad.
- IR Flashers—Models MF1, MF2, MF1VF, MF2VF and the IRB1.

An IR sensor expansion hub, Model IRH610, is available to provide additional sensor inputs to your system.

Features and Benefits

The CS100 offers a number of improvements over other miniature IR sensors.

- Plasma-proof performance—allows placement of the CS100 near plasma displays.
- CFL interference resistant—expands installation flexibility to areas with fluorescent lighting.
- Works under most lighting conditions, including indirect sunlight—eliminates environmental restrictions.
- Universal system—compatible with virtually all brands of A/V equipment and remote controls.
- Excellent IR receiving range—you get 18' to 30' of remote control range (depending upon the strength of your hand-held remote).
- 100% factory tested for pickup range and angle.
- Small size of only 1-5/8" diameter by 3" long—fits almost anywhere.
- 10' of connecting wire included.
- Printed circuit board design uses surface mount technology (SMT), assuring high reliability.
- Ideal for both home and commercial installations.
- Each CS100 includes a transparent cover.
- Two year parts and labor warranty.

IMPORTANT

Refer installation to a professional custom installer if you are unfamiliar with any of the following procedures.

**TOOLS
REQUIRED**

- 1/8" Standard Slotted Screwdriver
- Adjustable wrench or pliers
- Wire Stripper

Installation Considerations**Type of Cable**

The CS100 connects to the Niles Infrared main systems unit or IRH610 sensor expansion hub with an individual home run of category 5 cable. When running wires inside walls, most states and municipalities in the U.S. specify that you must use a special type of wire. Usually, the requirement is that the wire has a specific "CL" fire rating, such as "CL-2" or "CL-3". Consult your Niles dealer, building contractor, or local building and inspection department if unsure about which type of wire is best for your application.

CS100 Mounting Location

The CS100 is designed to be ceiling mounted in a direct line of sight location within the operating range of the remote control.

Receiving Range and Pickup Angle

The receiving range of the CS100 will vary according to the IR output strength of the remote control being used. Remote strength varies among brands depending on the number and size of batteries used, and how many IR emitters the remote has. For example, remotes that operate on two small AAA batteries and have only one IR emitter are generally not as strong as remotes that use the larger AA size batteries and have two emitters. Tests with various manufacturers' remote controls have shown that the operating range can vary from a minimum of 18' to a maximum of about 30'.

Infrared signals travel essentially line-of-sight. They will not pass through or around solid objects. Do not rely on an IR signal being able to "bounce" off a wall or object to the CS100.

The IR pickup angle of the CS100 is 30° off-axis (horizontal and vertical) at 20'.

Avoiding Interference

CS100 is designed to work in most applications including plasma displays and in areas where CFL lighting and indirect sunlight are present. You should avoid locating the CS100 near potential sources of electrical or optical noise, such as light dimmers or low-voltage lights.

Avoiding Optical Feedback

If installing the CS100 in the same room as an IR flasher, it is possible for the flasher's IR output to be picked-up by the CS100. This effect, known as an optical feedback loop, can cause erratic operation. Optical feedback is similar to acoustic feedback: the howling or whistling sound heard in a P.A. system when the microphone is too close to the speaker. To avoid optical feedback:

1. Re-position the flasher(s) and/or the sensor.
2. Use Niles MF1 or MF2 Microflashers and cover them with the supplied IR blockers.

Using the CS100 with the Intellipad Ci system.

The CS100 is fully compatible with the Niles Intellipad Ci line, follow the wiring instructions in Figure 5. For specific information see your Intellipad Ci manual.

CEILING MOUNT INFRARED SENSOR

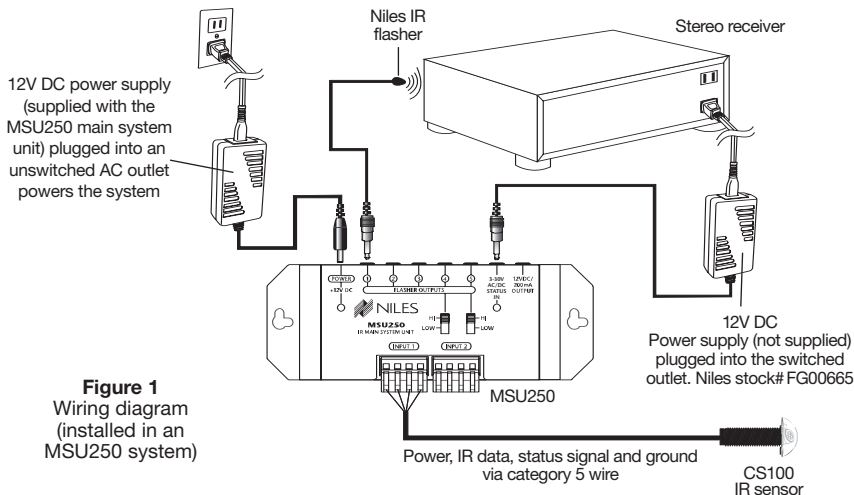

Figure 1
Wiring diagram
(installed in an
MSU250 system)

Red = 12V+
Black = Ground
Yellow = Data
White = Status

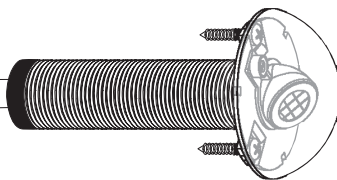

Figure 2
Wiring legend

CEILING MOUNT INFRARED SENSOR

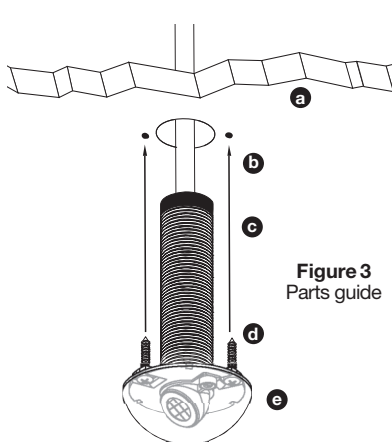

Figure 3
Parts guide

- (a) Mounting surface
- (b) IR Cable (10 feet supplied)
- (c) CS100 Miniature IR Sensor (supplied)
- (d) Installation screws (supplied)
- (e) CS100 lens bezel (supplied)

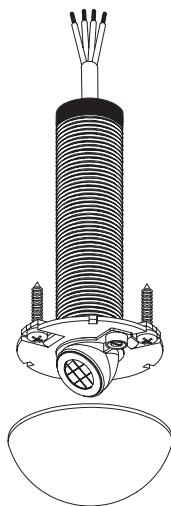
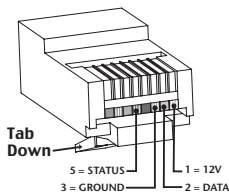

Figure 4
Removing the bezel

Figure 5 : Suggested wiring of CS100 to Niles IntelliPad Ci keypad via an RJ45 jack.



- 1 = Green/White - 12V
- 2 = Green - DATA
- 3 = Orange/White - GROUND
- 4 = Blue - EMPTY
- 5 = Blue/White - STATUS
- 6 = Orange - EMPTY
- 7 = Brown/White - EMPTY
- 8 = Brown - EMPTY

Installation

If you are installing the CS100 into an existing ceiling, take time to consider any possible obstructions which may be hidden, such as wood or metal studs, electrical, telephone or other types of wiring, plumbing, AC or heating conduits, etc.

1. Determine a mounting location for the CS100.
2. Drill a 7/8" hole where the CS100 will be mounted.
3. Run the CS100's IR cable. Label the cable for future reference (Figure 2). The CS100 is supplied with 10' of pre-stripped IR cable. The IR cable may be shortened or lengthened as needed. If you want to make the CS100's cable shorter, use a pair of wire cutters to cut the cable to the desired length. The IR cable may be lengthened by splicing it to a recommended IR cable (See Installation Considerations—Type of Cable). You may splice the CS100 cable to another cable by soldering or crimping the connections.
4. Fasten sensor to ceiling with supplied screws (Figure 3).
5. Connect the CS100 cable to the main system unit (Figure 1). Strip 1/4" of insulation from the end of each wire. Tightly twist the end of each wire until there are no frayed ends. Insert each wire into the appropriate hole on the removable connector plug, and snap the locking tab down.

To help you, the connector plug is keyed. Insert the smooth side of the connector plug into the smooth side of the socket. Don't force the scalloped side of the connector plug into the smooth side of the socket. Refer to the main system main system unit manual for specific installation instructions

Operation

Operation of the CS100 is straightforward. Simply aim your hand-held remote at the CS100. Your IR command is instantly repeated to your A/V equipment.

Troubleshooting

This manual contains instructions for the CS100 only. For specific information on the adjustment and operation of your Niles infrared extender system, please refer to the instruction manual included with your Niles IR main system unit (MSU140, MSU250, MSU480, MSU440Z, IntelliControl).

1. Test the remote control(s) by operating the A/V equipment directly. Replace the batteries if needed.
2. Double check the cable connections on the CS100 and on the main system unit. Look for open, shorted or reversed wires (Figure 2).
3. Test for interference from the following sources:
 - Neon or halogen lights in the room
 - Light dimmers, beginning with those closest to the CS100

Observe the main system unit IR confirmation LED while performing all the tests. It is possible to have interference from more than one source.

Eliminating Optical Feedback

In some installations, two conditions combine to create an optical feedback loop. Symptoms can include: poor range, intermittent operation or no operation.

The conditions which sometimes combine to create a feedback loop are:

1. Both a sensor and a flasher are located within the same room.
2. There is some low-level noise or interference on your system.

You can eliminate optical feedback by replacing any IRB1 “flooding flasher” with MF1 or MF2 MicroFlashers and covering all flashers with the supplied IR blocking covers.

EMI (Electromagnetic Interference)

Identify the source of the interference. The most common sources of electromagnetic interference are listed in the Installation Considerations section on pages 3 and 4. To eliminate EMI try the following methods:

1. Move the sensor or the sensor cable away from the EMI source **or** move the source of the EMI away from the sensor or the cable.
2. Connect the Sensor’s GND terminal to true earth ground (if this isn’t feasible use the main system unit’s GND terminal).

There are many methods for reducing interference. Which solution is best for you depends on your situation. Contact Niles Technical Support at 1-800-289-4434 if you require further assistance.

Specifications

IR System

Compatible with virtually all brands of remotes using carrier frequencies between 26 and 105 kHz

IR Receiving Range

Varies depending on remote strength; 18' to 30' typical

IR Receiving Angle

30° off-axis (horizontal and vertical) at 20'

Mounting

Thru-hole, fits into a 7/8" diameter hole; requires a minimum of 2-1/2" mounting depth

Wiring Requirements

Individual home-runs of category 5 cable

Unit Dimensions

Front Bezel: 1-5/8" diameter x 11/16" high

Overall Unit: 11/16" diameter x 3" long

Contents

CS100 Miniature IR Sensor x 1

Installation Screws x 3

CS100 Lens Bezel x 1



NILES®

**Niles Audio
Corporation**

www.nilesaudio.com

12331 S.W. 130 Street
Miami, Florida, 33186
Tel: (305) 238-4373
Fax: (305) 238-0185

©2004 Niles Audio Corporation. All rights reserved. Niles, the Niles logo, IntelliControl and Blending High Fidelity and Architecture are registered trademarks of Niles Audio Corporation. MicroFlasher is a trademark of Niles Audio Corporation. Because we strive to improve our products, Niles reserves the right to change product specifications without notice. The technical and other information contained herein is not intended to set forth all technical and other specifications of Niles products. Additional information can be obtained on-line at www.nilesaudio.com or by calling Niles at 1-800-289-4434. 01/04 Printed in China DS00349ACN