



NILES®



INSTALLATION GUIDE



FOR USE IN DISTRIBUTED AUDIO OR HOME THEATER SYSTEMS
INDOOR/OUTDOOR WEATHERPROOF LOUDSPEAKERS

OS7.3 OS6.3 OS5.3

CONGRATULATIONS!

Thank you for choosing Niles **OS Indoor/Outdoor Loudspeakers**. With proper installation and operation, you'll enjoy years of trouble-free use.

Niles manufactures the industry's most complete line of custom installation components and accessories for audio/video systems. To see the complete Niles product assortment, visit us on the Internet at: www.nilesaudio.com

TABLE OF CONTENTS

Introduction	1
Features and Benefits	2
Parts Guide	4
Installation Considerations	6
Painting the Loudspeaker	11
Installation	14
Operation	17
Specifications	18
Notes	19
Warranty	20
Warranty Registration Card	21



INTRODUCTION

Niles once again raises the bar. With our first OS Indoor/Outdoor models, we revealed a radical new understanding of loudspeaker capabilities. Niles original OS Indoor/Outdoor Loudspeakers are constantly praised for their ability to deliver exemplary reliability and outstanding sound quality. These attributes have made Niles OS Indoor/Outdoor Loudspeakers the bestselling loudspeakers in their class.

The goal of our new OS Indoor/Outdoor line-up is to raise this bar with refined appearance and superior sonic performance, once again establishing a benchmark by which all others are judged. The new Niles OS Indoor/Outdoor Loudspeakers owe much of their performance and sound quality advantage to design elements pioneered in the award-winning Niles DS Directed Soundfield™ Loudspeakers. Their engineering advances come from our integrated approach to driver and cabinet design. By integrating the woofer basket into the baffle of the cabinet, we are able to increase the woofer cone-area to cabinet-width ratio, thus enabling OS Indoor/Outdoor Loudspeakers to provide levels of bass performance that substantially exceed their physical size. However, deeper and more powerful bass isn't the only refinement in the new OS Indoor/Outdoor line-up. A new and modern style enables OS Indoor/Outdoor Loudspeakers to blend seamlessly with architectural elements, both indoors and out. After the installation is complete, you will be astonished by the experience of hearing such clean and powerful sound coming from such elegant-appearing loudspeakers.



FEATURES AND BENEFITS

LIMITED LIFETIME WARRANTY

We engineer bulletproof reliability into all OS loudspeakers and back them up with our industry-leading Limited Lifetime Warranty

INTEGRATED WOOFER/BAFFLE ASSEMBLY

Increases the woofer cone-area to cabinet-width ratio for enhanced bass output.

MICA-FILLED POLYPROPYLENE WOOFER CONE

Reduces breakup and lowers distortion.

BUTYL-RUBBER WOOFER CONE SURROUND

Damps resonance and provides exceptional durability.

ULTRASILK® DOME TWEETER

One-inch fluid-cooled tweeter provides ultra-wide dispersion for clear, detailed, and extended high-frequencies.

WEATHERPROOF ENGINEERING

Enables OS loudspeakers to handle extreme hot, cold, and moist environments, exceeding the military's strict anti-corrosion specification MIL-STD-883D.

ADVANCED MATERIAL SCIENCE

Elevates appearance and longevity of the cabinet and grille, plus enhances the performance of the woofers, tweeters and crossovers.

ARCHITECTURALLY-FRIENDLY DESIGN

Delivers stellar acoustical performance, yet tucks discreetly away into corners and under eaves.

LOW-DIFFRACTION GRILLE AND FRONT BAFFLE

Ensures that the sound waves emanating from the woofer and tweeter are not reflected by the surrounding parts of the loudspeaker for precise imaging and acoustical accuracy.



RIGID, ACOUSTICALLY-INERT CABINET

Prevents transmission of unwanted vibrations for clean and dynamic bass response.

ALL-WEATHER VERSATILITY

Reduces installation limitations to provide great sound from the beaches of Miami to the harsh winters of Minneapolis.

HOME THEATER APPLICABILITY

Enables OS loudspeakers to be used as left, center, right, or surround loudspeakers in home theater systems.

INTEGRATED MOUNTING BRACKET AND SHELF STAND

Provide a variety of secure, quick and easy mounting solutions.

TAPERED SHAPE

Facilitates mounting in corners and under eaves.

INVERTED GOLD-PLATED 5-WAY BINDING POSTS

Repel moisture and ensure positive connections in virtually any conditions over long periods of time.

PARTS GUIDE

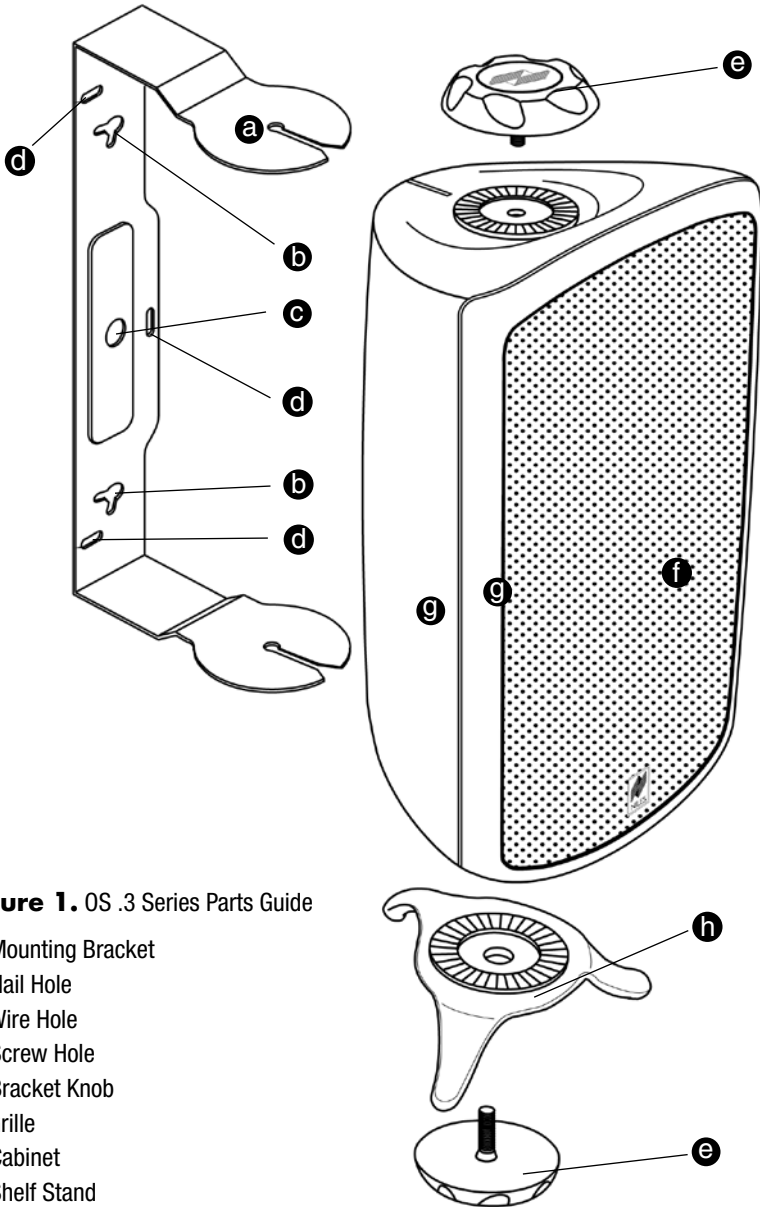

Figure 1. OS .3 Series Parts Guide

- a. Mounting Bracket
- b. Nail Hole
- c. Wire Hole
- d. Screw Hole
- e. Bracket Knob
- f. Grille
- g. Cabinet
- h. Shelf Stand

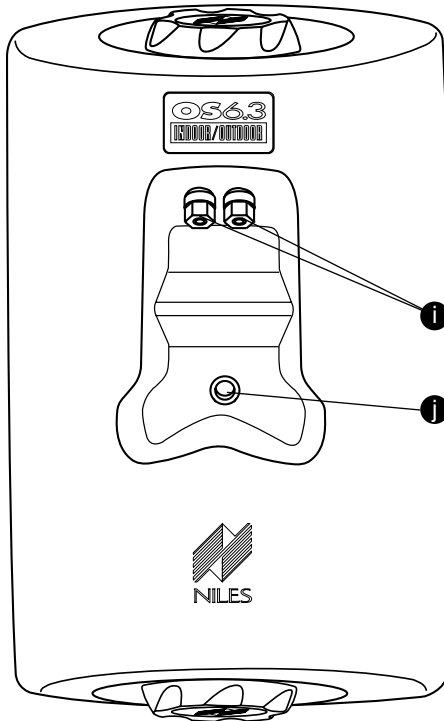

Figure 2. OS .3 Series Parts Guide (continued)

i. Binding Posts

j. Threaded Insert (1/4"-20 Thread size)

NOTE: Bracket and Shelf Stand are used depending upon installation requirements.

See **INSTALLATION** on page 14.

INSTALLATION CONSIDERATIONS

TOOLS AND MATERIALS REQUIRED

- *Electric drill with 1/4- and 1/2-inch drill bits, and a 1-inch flat drill bit (for drilling through studs)*
- *Three screws or bolts suitable for the mounting surface*
- *The proper screwdriver for the mounting hardware*
- *Safety cable (optional)*
- *Cable ties*
- *Wire stripper*
- *Pencil*
- *Level*
- *Rubber gloves and protective eyewear*

WIRING

The OS loudspeakers connect to your receiver or amplifier using 2-conductor loudspeaker wire (see **Figure 3** on the next page). For most applications, we recommend using 16- or 18-gauge wire. For wiring runs longer than 80 feet, we recommend 14-gauge wire. The binding posts on OS loudspeakers accommodate up to 12-gauge wire directly. Larger sizes can be accommodated using spade, banana, or pin connectors.

TECH TIP

Wire size is expressed by its AWG (American Wire Gauge) number – the lower the number, the larger the wire. For example, 12 AWG is physically larger than 14 AWG.

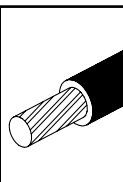

When you run wire inside walls, outdoors or in marine installations, special jacketing or conduit is required for a trouble-free installation and conformation to the local and national building codes. If you are not sure of the correct wire jacket or type of conduit to use, consult a professional audio/video installer, building contractor, or the local building and inspection department.

INCORPORATING A VOLUME CONTROL

It's possible to control the volume of the sound at the loudspeaker location. Plan to wire the system so that each pair of loudspeakers has its own volume control. Niles makes a wide range of indoor and outdoor volume controls with and without muting capabilities. Consult your local Niles dealer for more information. Volume controls are connected in line with the loudspeaker, so you must connect the wire from the amplifier to the volume control and then from the volume control to the loudspeaker (see **Figure 4** on the next page).

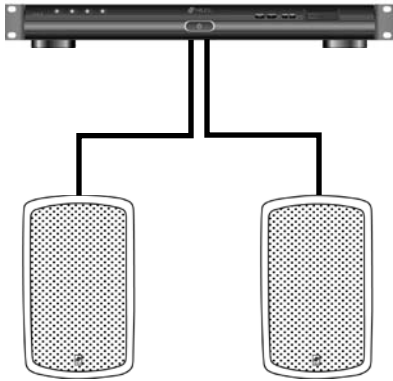

Figure 3. Wiring directly from a receiver or amplifier

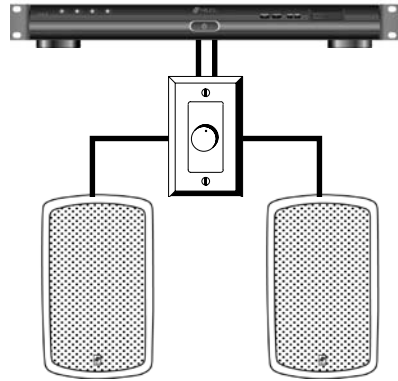

Figure 4. Incorporating a volume control

RECOMMENDED AMPLIFIER POWER

For optimum performance, we recommend amplifiers with the following power ratings:

- For the OS 5.3 loudspeaker, 5 to 100 W per channel
- For the OS 6.3 loudspeaker, 5 to 125 W per channel
- For the OS 7.3 loudspeaker, 5 to 150 W per channel

Ironically, most loudspeakers are not damaged by large amplifiers but by small amplifiers. If you are playing at high volume, a small amplifier will run out of power very quickly. When an amplifier runs out of power it creates damaging “clipping” distortion. A large amplifier will play at the same volume without distorting. See **OPERATION** on page 17 for more information about clipping distortion.

PLACING LOUDSPEAKERS FOR THE BEST SOUND QUALITY

An OS loudspeaker’s dispersion pattern is very broad. This allows good sound quality over an extremely large listening area. However, if a single pair is positioned to provide coverage of a very large room or patio, you will have “hot spots” of loud sound when you are near the loudspeakers. The best way to avoid hot spots for a large space is to use several pairs of loudspeakers evenly spaced throughout the room. A good rule of thumb is to install a pair of loudspeakers for every 200 to 400 square feet of listening area. Your local Niles dealer is a good source for advice on loudspeaker placement for your particular installation.

(CONTINUED ON NEXT PAGE)

PLACING LOUDSPEAKERS FOR THE BEST SOUND QUALITY (CONTINUED)

When using more than one pair, it is usually best to alternate a left channel and then a right channel, so that you have the best possible stereo coverage possible.

The position of the loudspeakers and their surroundings play a very important role in how a stereo image is created. You should experiment to find the very best position for your loudspeakers. Here are some guidelines to make the process quick and easy.

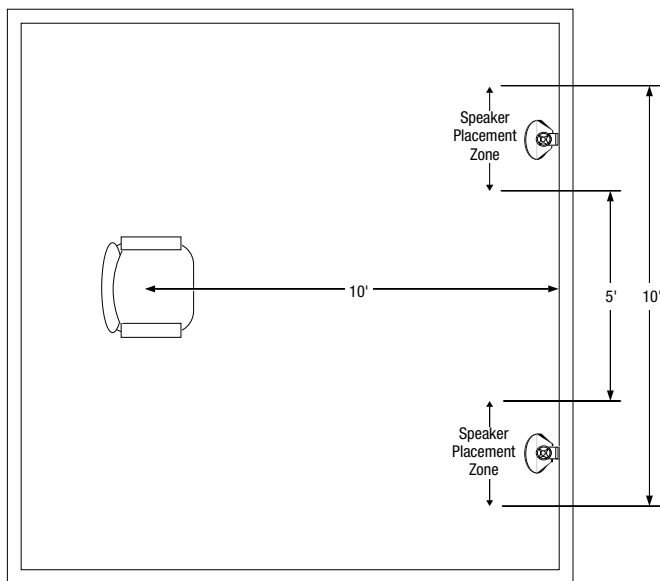

Figure 5. Illustration depicts the optimum placement zone for a listening distance of 10 feet.

Make sure you are not blocking or reflecting the sound off of furniture or other objects. You should have a direct line of sight with the front of the loudspeaker. To determine the best position, measure the distance between the ideal listening position and the wall you plan to mount the loudspeakers on. Try to place the loudspeakers so that they are at least one-half the listening distance apart (this maintains a large, pleasant stereo “image”) and less than the entire listening distance (this avoids a “hole-in-the-middle” effect). For example; if you are ten feet back from the wall, the loudspeakers should be between 5 and 10 feet apart (see **Figure 5**).

If possible, mount the loudspeakers between 8 and 12 feet high. The less the downward angle of the loudspeaker, the further the sound will carry. If the sound is carrying into areas where you do not want sound, try pointing the loudspeakers more downward; this will reduce the amount of sound further away from the loudspeaker.



You can control the loudspeaker's bass output by placement. This is called the boundary effect. You will get more bass response by mounting the loudspeaker directly to a wall or other flat surface (any boundary close to the loudspeaker will reinforce the bass frequencies). You can increase the bass output even more by mounting the loudspeaker in a corner or under an eave (see **Figure 6**) This type of placement gives the loudspeaker two boundaries, thus reinforcing the bass sounds even more. Of course, if you wish to hear less bass, try moving the loudspeaker away from the boundary (see **Figure 7**).

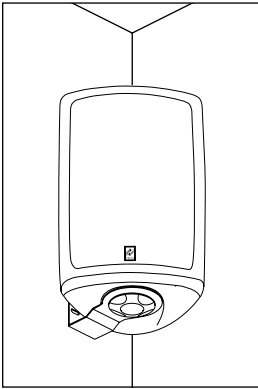

Figure 6. Placement for more bass output.

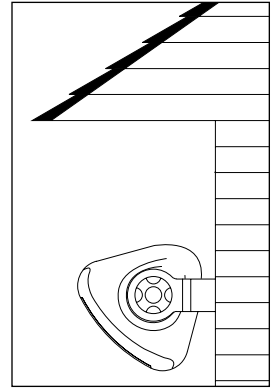
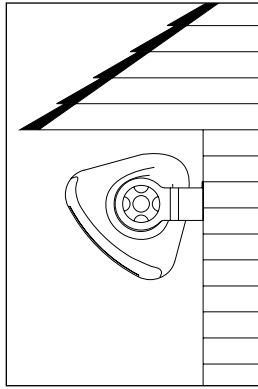

Figure 7. Placement for less bass output.

MOUNTING METHODS

The OS loudspeakers can be mounted either horizontally or vertically. The bracket knobs will keep the loudspeaker angled correctly in any position once they are tightened. You can choose from three mounting methods to attach the loudspeaker to the wall, ceiling, or other mounting surface.

1. *If the loudspeaker is never going to be exposed to sudden accidental impacts, wind, waves, or earthquakes, you can simply hang it on a nail using the nail hole(s) on the bracket (see **Figure 8** on the next page).*
2. *The safest and most secure way to mount the loudspeaker is by screwing it to the mounting surface using your own hardware (suitable for the surface you are mounting to) and the bracket supplied with the loudspeaker (see **Figure 8**).*
3. *There is a threaded brass insert (1/4" – 20) on the back of the OS loudspeakers for attaching a custom bracket (see **Figure 8**). This allows you to position the loudspeaker at unusual angles or varying distances from the mounting surface.*

(CONTINUED ON NEXT PAGE)

MOUNTING METHODS (CONTINUED)

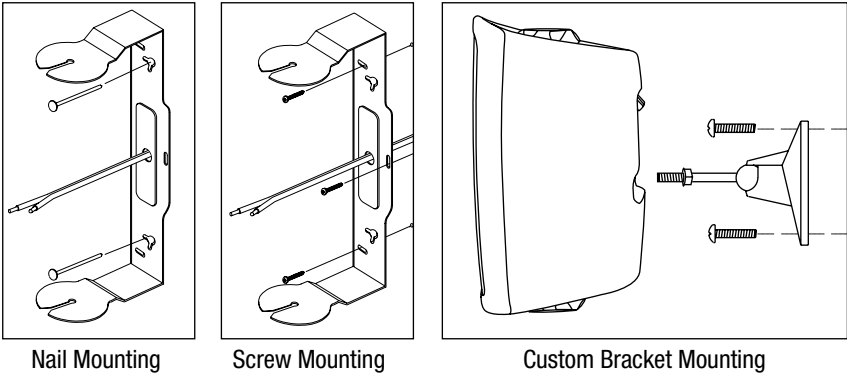

Figure 8. The OS loudspeakers can be mounted three ways.

SAFETY FIRST!

Be careful to use hardware that is designed for the surface you are mounting to. The OS 5.3 loudspeaker with the bracket weighs 5-1/2 pounds. The OS 6.3 loudspeaker with the bracket weighs 6-1/2 pounds. The OS 7.3 loudspeaker with the bracket weighs 9 pounds. We recommend using attachment methods capable of supporting ten times the weight of the loudspeaker and bracket.

Some local building codes require the use of an additional safety cable to mount loudspeakers on a wall. If so, the 1/4"-20 threaded insert on the rear of the enclosure can be utilized for securing the safety cable to the enclosure. Construction of the safety cable and attachment of the cable to the wall need to meet the local building codes.

If you are not sure of a safe way to mount the loudspeakers or are unsure of your local building codes, consult a professional installer or a building contractor for the proper installation techniques and requirements.

You will maximize the useful life of the loudspeaker by placing the loudspeaker so that it receives less exposure to the elements. Look for the best overall compromise between sound quality, convenience, and exposure. Do not compromise safety.

PAINTING THE LOUDSPEAKER

The enclosure, the brackets, and the grilles of the loudspeaker can all be painted to match the surroundings. Because we want you to preserve the acoustic qualities of the grille, please paint the grille according to the grille painting instructions. Make sure you pick a paint that is appropriate for the mounting location. There are interior and exterior paint types, and even paint for marine uses. If you are not sure what paint to use, consult a paint store professional or a painter.

TOOLS REQUIRED

- *Spray can of primer paint*
- *The correct paint for the environment/use (oil- or water-based paint is fine)*
- *Paint brush or applicator (if the paint is not in a spray can)*
- *Awl (for removing the grille)*
- *Masking tape*
- *Two paint masks (supplied)*
- *A damp cloth and a dry cloth*

PREPARING TO PAINT

1. *Separate the parts of the loudspeaker. You should remove the brackets and the bracket knobs. Remove the grille by hooking it with the tip of an awl and pulling it away from the cabinet (see **Figure 9** on the next page).*
2. *Wipe off the sides of the cabinet, the bracket, bracket knobs, and grille with a damp cloth. Do not touch or rub the loudspeakers on the front baffle. Make sure everything is dry before masking.*
3. *Mask off the binding posts and the brass threaded inserts on the back panel with masking tape.*

(CONTINUED ON NEXT PAGE)

PREPARING TO PAINT (CONTINUED)

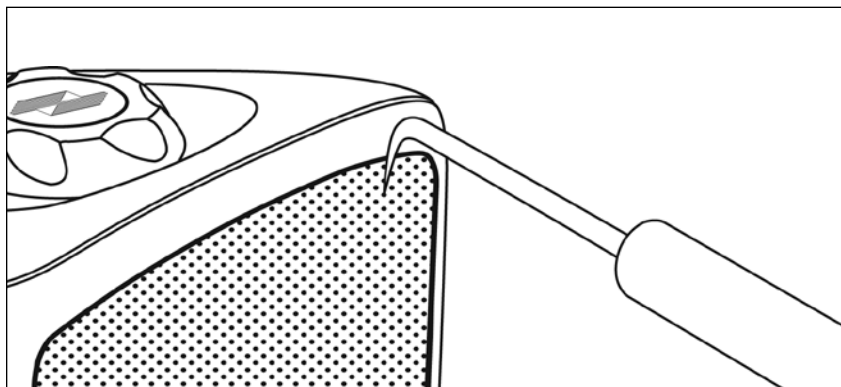

Figure 9. Removing the grille using an awl.

4. *Mask off the threaded inserts on the top and bottom with masking tape.*
5. *Protect the front of the loudspeakers by inserting the supplied paint masks in place of the grilles.*

PAINTING THE CABINET, BRACKET KNOBS, AND BRACKET

1. *Apply two thin coats of a sandable spray primer to the cabinet and knobs. The bracket doesn't require a coat of primer.*
2. *Allow the primer to dry completely.*
3. *Apply the finish color.*
4. *Allow the paint to dry completely.*
5. *Carefully remove the masking material.*
6. *Do not reattach the loudspeaker to the bracket until the bracket is mounted. Try to keep all handling of the freshly-painted parts to a minimum.*



PAINTING THE GRILLE

The grille is important to the sound of the loudspeaker. Do not fill the holes of the grille with paint. The grille is constructed of aluminum with a perfectly-even powder coat overall. This powder coat is an ideal primer.

If you are using a spray paint, use two thin coats without any primer. If you are using a compressor and a spray gun, use the finest, most diffuse setting. Practice on paper if you are not experienced in painting with spray paint.

If you are using an applicator or brush and a can of paint, thin the paint first. Thick paint will tend to clog the grille holes. To ensure a uniform appearance, paint the front and back of the grille.

REPLACING THE GRILLE

After the grille dries, carefully fit the grille into its recess so that it is barely in place. Starting with one corner, go around the loudspeaker, pushing in the grille a little bit each time, and making sure not to bend the grille out of shape. You will feel a positive “snap” when it is in place.

INSTALLATION

MOUNTING THE BRACKET (IF ATTACHING THE LOUDSPEAKER TO A WALL, CEILING, BEAM, OR OTHER SOLID STRUCTURE)

1. Loosen the bracket knobs and remove the bracket from the loudspeaker.
2. Hold the bracket up to the mounting surface. The loudspeaker can be mounted either horizontally or vertically. Hold the bracket so that the loudspeaker wire fits through the large, circular wire hole in the center of the bracket. Align the bracket so it is square with the surroundings (use a level for accuracy).
3. Mark the locations of the three oval-shaped screw holes (see **Figure 10**). Be sure to use all of the holes.

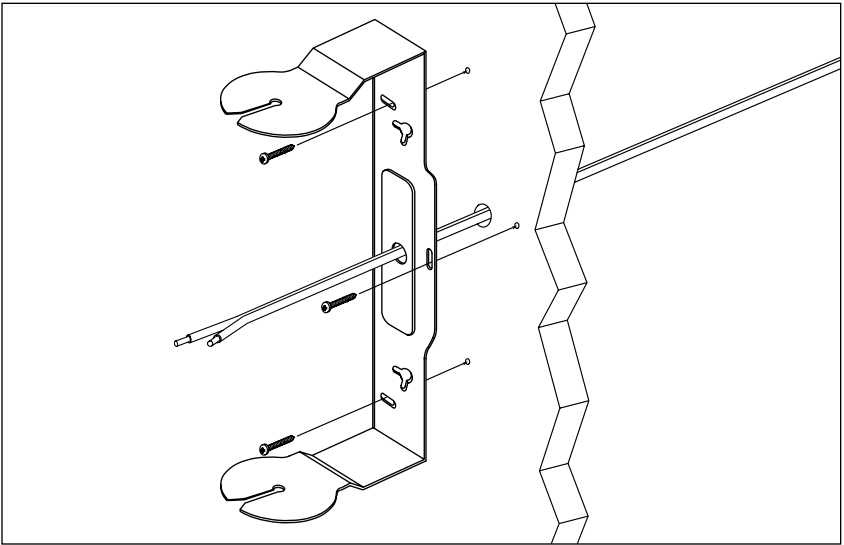

Figure 10. Mounting the Bracket

4. Drill pilot holes into the mounting surface.
5. Pull the loudspeaker wire through the wire hole in the center of the mounting bracket. Align the bracket so that the holes all line up.
6. Use your hardware to attach the bracket to the mounting surface.



ATTACHING THE FOOT (IF USING THE LOUDSPEAKER IN FREE-STANDING MODE)

1. Loosen the bracket knobs and remove the bracket from the loudspeaker.
2. Tighten the top knob so it does not vibrate.
3. Remove the bottom knob by unscrewing it from the cabinet.
4. Place the supplied shelf stand on the loudspeaker with the two shorter feet towards the front of the loudspeaker (see **Figure 11**). Make sure the ridges on the shelf stand engage the ridges on the cabinet.
5. Tighten the bottom knob so that the shelf stand does not move.

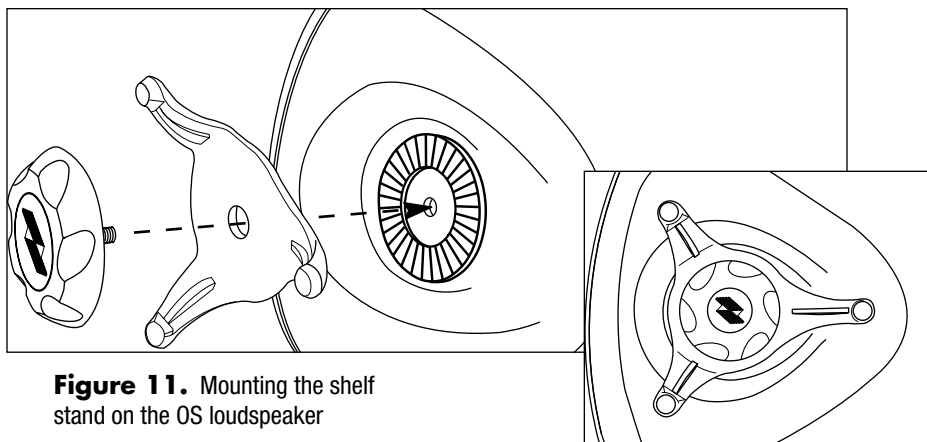

Figure 11. Mounting the shelf stand on the OS loudspeaker

Bottom of Speaker

CONNECTING THE LOUDSPEAKER

1. Separate the two conductors of the loudspeaker wire so that at least 2 inches of each conductor are free.
2. Strip away 1/2 inch of insulation from the end of each conductor of the loudspeaker wire.
3. If you have any connectors (gold pins or bananas) which you prefer to use, affix them to the stripped wire ends now. Only gold-plated connectors should be used outside, as they will not tarnish or corrode.

(CONTINUED ON NEXT PAGE)

CONNECTING THE LOUDSPEAKER (CONTINUED)

4. *If using the bracket to attach to a solid surface, slide the loudspeaker onto the bracket. Do not tighten the knobs completely. Angle the loudspeaker so that the rear terminals are accessible. If using the shelf stand, position the loudspeaker on the stand and place it on the shelf or table where you want it.*
5. *Connect one stripped wire end to the black terminal and one to the red terminal, using correct polarity.*

NOTE: OBSERVE CORRECT POLARITY: POSITIVE (+) GOES TO THE RED POST AND NEGATIVE (-) GOES TO THE BLACK POST. IF YOU ARE UNSURE OF WIRE POLARITY, SEE **CHECKING LOUDSPEAKER PHASE** BELOW.

6. *If required, attach the safety cable to the loudspeaker enclosure. See **SAFETY FIRST** on page 10 for details.*
7. *Verify that the loudspeakers are in-phase, as described in **CHECKING LOUDSPEAKER PHASE** below.*
8. *Angle the loudspeaker for the best sound possible.*
9. *Tighten the bracket knobs by hand only.*

NOTE: DO NOT USE ANY TOOLS FOR TIGHTENING. DOING SO MAY STRIP THE INSERT THREADS.

10. *Check that the entire installation is safe and secure.*

CHECKING LOUDSPEAKER PHASE

Loudspeaker wire has two conductors. On both your loudspeaker and amplifier, one conductor is attached to the negative (-) terminals, while the other is attached to the positive (+) terminals. Usually, the wire is marked for your convenience, but the marking can be done in the following different ways:

- *Stripe on one wire*
- *Ribbed area you can feel on one conductor*
- *Different colors of metal wire on each conductor*
- *Fabric strand or string wound into one of the conductors*

Of course, there are some wires that appear completely identical. So be careful, or you might make a connection mistake. If you do, one loudspeaker will be playing “out-of-phase” with the other loudspeaker. A pair of out-of-phase loudspeakers works against each other, and the sound of the two playing together will be lacking in bass and sound “phasey.” If you suspect the sound is not right, and you cannot see any markings on the wire, try this simple test:

- 
1. *Stand halfway between the loudspeakers.*
 2. *Play some music with the amplifier or receiver set to Mono.*
 3. *Listen to the richness of the bass and the loudness of the sound.*
 4. *Turn off the amplifier and reverse the connections on one amplifier channel only.*
 5. *Repeat the listening test with the same volume control setting. When the sound has a richer bass and is slightly louder, the loudspeakers are working together or “in-phase.”*

OPERATION

LISTENING AT HIGHER VOLUMES

Outdoors there are no walls to reflect and contain the sound. It requires more power to achieve a reasonable volume of sound outside than it does indoors. You also frequently find yourself very far from the loudspeakers. It is possible to turn the volume so high that the amplifier runs out of power. This creates “clipping” distortion.

Clipping distortion makes treble sound very harsh and unmusical. When you hear harsh sounding treble from any good loudspeaker indoors or outdoors, turn the volume down immediately! Those harsh sounds are masking some much more powerful ultra-high-frequency sound spikes which will quickly damage any fine loudspeaker.

CLEANING

Clean the OS loudspeakers with a dampened soft cloth or paper towel. If the loudspeaker is mounted high up on a wall or ceiling, use a broom to gently brush it off. Hosing off the loudspeaker is not recommended, as the tweeter is a precise mechanism which might be damaged by a high-pressure stream of water.

SPECIFICATIONS

OS 7.3 Loudspeaker

Driver Complement

- 7" mica-filled polypropylene woofer
- 1" Ultrasilk dome tweeter with fluid cooling

Recommended Amplifier Power

5 to 150 watts per channel

Nominal Impedance

8 ohms

Frequency Response

65 Hz to 21 kHz, +/- 3 dB

Sensitivity

91 dB with 2.83 V pink noise input, measured at 1 meter on axis

Wiring Requirements

We recommend using 16- to 18-gauge speaker wire for runs up to 80 feet and 14-gauge speaker wire for runs up to 200 feet. The connectors will accommodate 12- to 22-gauge wire.

Dimensions (Loudspeaker with U-Bracket)

8-3/16" Wide x 14-1/2" High x 9-3/16" Deep

Weight (Loudspeaker and Bracket)

18 lb per pair (8.1 Kg)

OS 6.3 Loudspeaker

Driver Complement

- 6" mica-filled polypropylene woofer
- 1" Ultrasilk dome tweeter with fluid cooling

Recommended Amplifier Power

5 to 125 watts per channel

Nominal Impedance

8 ohms

Frequency Response

75 Hz to 21 kHz, +/- 3 dB

Sensitivity

90 dB with 2.83 V pink noise input, measured at 1 meter on axis

Wiring Requirements

We recommend using 16- to 18-gauge speaker wire for runs up to 80 feet and 14-gauge speaker wire for runs up to 200 feet. The connectors will accommodate 12- to 22-gauge wire.

Dimensions (Loudspeaker with U-Bracket)

7-7/16" Wide x 12" High x 7-3/4" Deep

Weight (Loudspeaker and Bracket)

15 lb per pair (6.8 Kg)

OS 5.3 Loudspeaker

Driver Complement

- 5" mica-filled polypropylene woofer
- 1" Ultrasilk dome tweeter with fluid cooling

Recommended Amplifier Power

5 to 100 watts per channel

Nominal Impedance

8 ohms

Frequency Response

100 Hz to 21 kHz, +/- 3 dB

Sensitivity

90 dB with 2.83 V pink noise input, measured at 1 meter on axis

Wiring Requirements

We recommend using 16- to 18-gauge speaker wire for runs up to 80 feet and 14-gauge speaker wire for runs up to 200 feet. The connectors will accommodate 12- to 22-gauge wire.

Dimensions (Loudspeaker with U-Bracket)

6-1/4" Wide x 9-7/8" High x 6-3/4" Deep

Weight (Loudspeaker and Bracket)

11 lb per pair (5 Kg)

LIMITED WARRANTY

Niles Audio Corporation ("NILES") warrants to the original retail purchaser only that this product will be free of manufacturing defects in material and workmanship for the following periods and subject to the limitations and exclusions set forth below:

Lifetime Warranty

All Passive Loudspeaker Products (those not requiring AC or battery power).

Ten years from the date of purchase

All Other Passive Products (those not requiring AC or battery power).

Two years from the date of purchase

All Active Products (those requiring AC or battery power).

This warranty is not transferable to subsequent purchasers of the product. To obtain warranty service, contact the authorized dealer where you purchased your product or take the unit to the nearest authorized NILES dealer (with proof of purchase – claims made without proof of purchase will be denied) who will test the product and if necessary, forward it to NILES for service. If there are no authorized NILES dealers in your area, you must contact NILES to receive a factory Return Authorization Number. **DO NOT RETURN ANY UNIT WITHOUT FIRST RECEIVING WRITTEN AUTHORIZATION AND SHIPPING INSTRUCTIONS FROM NILES.**

Upon examination, NILES will, at its sole option and expense, repair or replace any product found to be defective. NILES will return the repaired or replaced unit to you via its usual shipping method from the factory to your address in the United States of America or Canada only. Any shipping costs for addresses outside of the United States or Canada shall be the responsibility of the purchaser. In the event that this model is no longer available and cannot be repaired effectively, NILES, at its sole option, may replace it with a different model of equal or greater value, or refund the original purchase price paid. **THE FOREGOING ARE YOUR EXCLUSIVE REMEDIES FOR BREACH OF WARRANTY.**

This Warranty does not include service or parts to repair damage caused by improper use or handling, including but not limited to damage caused by accident, mishandling, improper installation, commercial use, abuse, negligence, or normal wear and tear, or any defect caused by repair to the product by anyone other than NILES.

This warranty does not cover reimbursement for your costs of removing and transporting the product for warranty service evaluation, or installation of any replacement product provided under this warranty.

This Warranty will be void if:

- the Serial Number on the product has been removed, tampered with or defaced.
- the product was not purchased from an authorized dealer or reseller.

THE FOREGOING WARRANTIES ARE EXCLUSIVE AND IN LIEU OF ALL OTHER EXPRESSED AND IMPLIED WARRANTIES. NILES EXPRESSLY DISCLAIMS ALL SUCH OTHER WARRANTIES, INCLUDING BUT NOT LIMITED TO IMPLIED WARRANTIES OF MERCHANTABILITY, FITNESS FOR A PARTICULAR PURPOSE AND NON-INFRINGEMENT, WITH RESPECT TO THE PRODUCT. TO THE MAXIMUM EXTENT PERMITTED BY LAW, NILES SHALL NOT BE RESPONSIBLE FOR ANY INCIDENTAL OR CONSEQUENTIAL DAMAGES EXCEPT TO THE EXTENT PROVIDED (OR PROHIBITED) BY APPLICABLE LAW, EVEN IF NILES HAS BEEN ADVISED OF THE POSSIBILITY OF SUCH DAMAGES.

Notwithstanding the above, if you qualify as a "consumer" under the Magnuson-Moss Warranty Act, or applicable state laws, then you may be entitled to any implied warranties allowed by law for the Warranty Period. Further, some states do not allow limitations on how long an implied warranty lasts or allow the exclusion or limitation of consequential damages, so such limitations may not apply to you. This warranty gives you specific legal rights, and you may also have other rights which vary from state to state.

For the name of your nearest authorized NILES dealer, contact: NILES AUDIO CORPORATION, P.O. BOX 160818, Miami, Florida 33116-0818, or call 1-800-289-4434, 1-305-238-4373. Please be advised that NILES only sells its products via the Internet through a select group of authorized Internet dealers. These are listed on our website at www.nilesaudio.com. Products offered on the Internet through unauthorized Internet dealers are not covered by the NILES warranty and may be either:

- 1) goods acquired on a secondary or grey market
- 2) counterfeit or stolen goods
- 3) damaged, or defective goods

Please fill in your product information and retain for your records.

Model _____ Serial No. _____ Purchase Date _____

ATTENTION: TO OUR VALUED CONSUMERS:

To insure that consumers obtain quality pre-sale and after-sale support and service, NILES products are sold exclusively through authorized dealers. This warranty is VOID if the products have been purchased from an unauthorized dealer.

WARRANTY REGISTRATION CARD

Model Purchased _____

Serial Number _____

Date Purchased (month/day/year) _____

Dealer Name and Location _____

Dr. Miss Mr. Mrs. Ms.

Name _____

Address _____

City _____ State _____ Zip _____

Telephone () _____

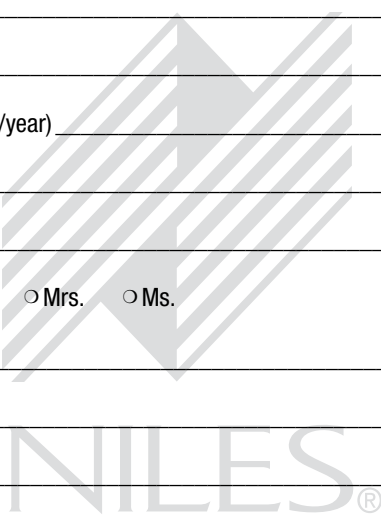

Please take a moment to fill out our warranty registration card. The information helps us to get to know you better and develop the products you want

Age:

- Under 25
- 25-34
- 35-44
- 45-54
- 55 & over

Income:

- Under \$24,999
- \$25,000-\$34,999
- \$35,000-\$44,999
- \$45,000-\$59,999
- \$60,000-\$74,999
- \$75,000-\$99,999
- Over \$99,999

Occupation:

- Arts/Entertainment
- Business Owner
- Engineer
- Finance/Accounting
- General Office
- Management
- Professional
- Sales/Marketing
- Student
- Tradesperson

Musical tastes:

(Please check all that apply)

- Alternative
- Classical
- Country
- Jazz
- New Age
- Popular
- R&B
- Rock
- Other _____

How did you hear about Niles?

- Architect/Developer
- Custom Installer
- Direct Mail
- Friend/Family
- In-Store Display
- Interior Designer
- Magazine Ad
- Mail-Order Catalog
- Newspaper Ad
- Product Brochure
- Product Review
- Retail Salesperson

What magazines do you read?

1. _____
2. _____
3. _____

Who will install the product?

- Custom Installer
- Electrician
- Friend
- Myself

Which factor(s) influenced the purchase of your Niles product? (Please check all that apply)

- Ease of Use
- Price/Value
- Product Features
- Quality/Durability
- Reputation
- Style/Appearance
- Warranty

Do you . . . ?

Own a House. If yes, how many square feet? _____

- Own a Town House/Condominium/Co-op
- Rent an Apartment
- Rent a House

Are you interested in receiving literature on other Niles products?
 Yes No

Are there products/capabilities that you would like to see introduced?

DETACH HERE AND RETURN TO: NILES AUDIO CORPORATION WARRANTY REGISTRATION DEPT. P.O. BOX 160818 MIAMI, FLORIDA 33116-0818



BLENDING HIGH FIDELITY AND ARCHITECTURE®

Niles Audio Corporation
12331 S.W. 130 Street Miami, Florida 33186
1-305-238-4373

1-800-BUY-HIFI - www.nilesaudio.com

©2009 Niles Audio Corporation. All rights reserved. Niles, the Niles logos, UltraSilk and Blending High Fidelity and Architecture are registered trademarks of Niles Audio Corporation. All other trademarks are the property of their respective owners. DS00425C