

FEATURES

- Artistically crafted cabinet with shaped MicroPerf™ aluminum grilles look natural and realistic
- 6.5" dual voice coil injection-molded TCC (talc, carbon, and ceramic) filled polypropylene woofer with butyl rubber surround
- Dual 1" fluid-cooled tri-laminate Teteron tweeters mounted at a custom angle for optimum dispersion
- Separate left and right channel inputs provide stereo sound in a single loudspeaker projecting quality stereo sound over a larger area than conventional loudspeakers
- Weatherproof design ensures performance outdoors
- Designed to accommodate live plants
- Dual 3-foot burial-rated connection cables with waterproof wire-nuts to insure trouble free connection
- Can be wired in one-speaker stereo-input mode or two-speaker stereo mode

SPECIFICATIONS
Recommended Amplifier Power

10 to 100 Watts

Nominal Impedance

8 Ohm, in one-speaker stereo mode

4 Ohm, in two-speaker stereo mode

Wiring Requirements

2-conductor direct burial cable at the following sizes depending on longest length of cable required (2 per speaker in one-speaker stereo mode):

Wire Gauge	Maximum Distance
16	60 ft (18 m)
14	100 ft (30 m)
12	160 ft (50 m)

Temperature Extremes

-50° to 185° Fahrenheit

-45° to 85° Celsius

Shipping Dimensions

12 1/2" high x 28" wide x 11 1/2" deep

Shipping Weight

35 lbs. (15.9 kgs.)



BLENDING HIGH FIDELITY AND ARCHITECTURE®

Niles Audio Corporation

12331 S.W. 130 Street Miami, Florida 33186

305-238-4373

1-800-BUY-HIFI www.nileaudio.com

©2007 Niles Audio Corporation. All rights reserved. Niles, the Niles logos and Blending High Fidelity and Architecture are registered trademarks of Niles Audio Corporation. All other trademarks are the property of their respective owners. DS00628A

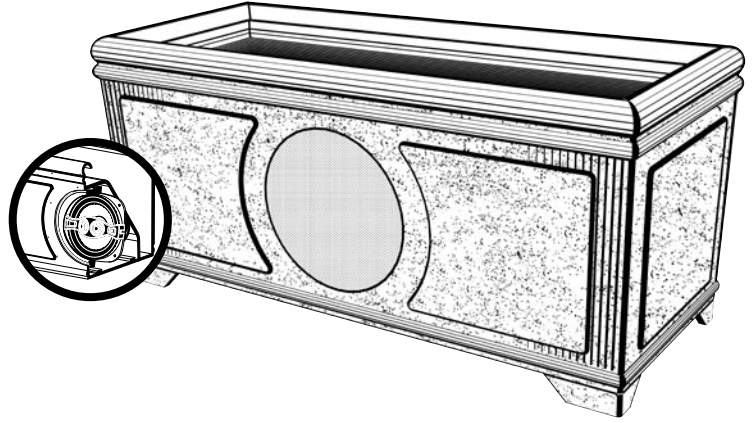
INSTALLATION GUIDE

FOR USE IN INDOOR OR OUTDOOR MUSIC SYSTEMS
STEREO INPUT PLANTER BOX SPEAKER

PB6Si

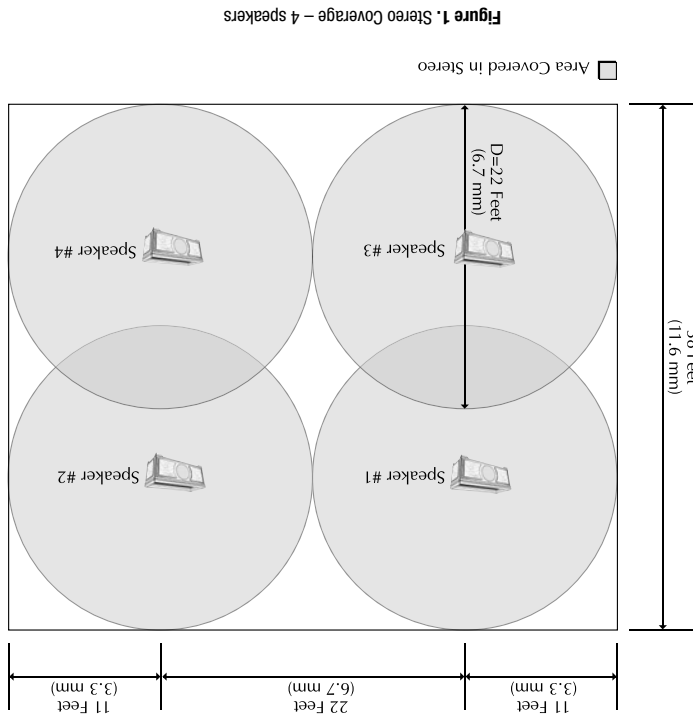
Figure 1. Stereo Coverage – 4 speakers

In one-speaker stereo mode, each connection cable of the PB6Si loudspeaker is connected to a separate amplifier channel and each loudspeaker cabinet plays in stereo. This configuration gives you the benefit of covering a larger area than the two-speaker stereo mode. The loudspeakers can be spaced 11 feet from the sides of the listening area and 22 feet from each other. The row spacing between speakers should be less than 38 feet. These loudspeaker spacing rules are the recommended maximums; placing speakers at a greater distance apart will negatively affect sound coverage and produce spots within the listening area where the sound quality will be poor.

SINGLE SPEAKER STEREO MODE

The PB6Si loudspeaker can be installed on a wood deck or on a concrete/stone patio. There are three considerations for placing the loudspeaker: connecting each cabinet in one-speaker stereo mode or two-speaker stereo mode, ease of running the cable to the loudspeaker and aimed on or near the loudspeaker. While the loudspeaker is weatherproof, continuous streaming water will shorten the product's life. The PB6Si loudspeaker will cover an area of a circle with a 22-foot diameter, in front of the speaker.

SELECTING THE NUMBER AND LOCATION FOR YOUR SPEAKERS

- Cable (length and type determined by installation site)
- A wire stripper

Tools and Materials Required:

INSTALLATION CONSIDERATIONS

Niles manufactures the industry's most complete line of custom installation components and accessories for audio/video systems. To see the complete assortment, visit our website at www.nileaudio.com.

Thank you for choosing the PB6Si Planter Speaker from Niles. With proper installation and operation, you'll enjoy years of trouble free use.

CONGRATULATIONS!

ONE-SPEAKER STEREO MODE VS TWO-SPEAKER STEREO MODE

One-speaker stereo mode has the advantage of covering a larger area than the two-speaker stereo mode. The trade off between the two configurations is volume. The two-speaker stereo configurations will be able to play louder in its area than the one-speaker stereo configuration.

INCORPORATING A VOLUME CONTROL

It is possible to control the volume of the sound at the speaker location. Volume controls are connected in line with the speaker. An example of wiring an area with 2 speakers and a master volume control is shown in **Figure 2** for one-speaker stereo mode, and **Figure 3** for two-speaker stereo mode. It is usually desirable to control the volume of the speakers in different areas or zones of the outdoor system. A suggested way to accomplish this is shown in **Figure 4** for one-speaker stereo mode, and **Figure 5** for two-speaker stereo mode.

Niles recommends our standard weatherproof volume control, WVC100 series or our weatherproof muting volume control, WMVC series. In addition to controlling the volume of the loudspeakers, these controls allow the addition of added speakers without adding more amplifier channels.

INSTALLATION

CONNECTING THE LOUDSPEAKER IN ONE-SPEAKER STEREO MODE

- Strip two to three inches of each speaker cable's outer jacket away from the insulated conductors. Ensure that at least two inches of the separate conductors are free.
- Strip one half inch of insulation from the end of each conductor for both connection cables.
- Observe proper phasing when performing the following: Choose the speaker cable that is labeled for the "Right" amplifier channel. Using a wire nut, connect one stripped end of the "Right" speaker cable to the PB6Si connection cable's red wire. The wire nut will protect the stripped ends of the wire. If added protection is desired, place a large amount of silicon sealant so the bottom of the wire nut is encased and sealed. Repeat with the PB6Si connection cable's black wire and the other stripped amplifier "Right" speaker cable's conductor.
- Repeat steps 3 and 4 for the "Left" speaker cable and the PB6Si's connection cable with the "yellow/black" pair of conductors.
- Connect the opposite end of the speaker cables to the amplifier or receiver. Start by performing step 1 and 2 on the speaker cable near the amplifier. Use the cable labeled "Right" and attach the same conductor you attached to the red loudspeaker wire to the positive (red) or (+) "Right" amplifier output terminal. Attach the other conductor in that cable to the amplifier's "Right" negative (black) or (-) amplifier output terminal.
- Using the cable labeled "Left" attach the same conductor you attached to the yellow loudspeaker wire to the positive (red) or (+) "Left" amplifier output terminal. Attach the other conductor in that cable to the amplifier's "Left" negative (black) or (-) amplifier output terminal.

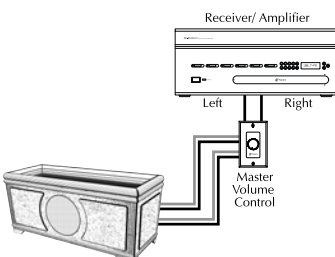

Figure 2. One-speaker stereo, one zone volume control wiring

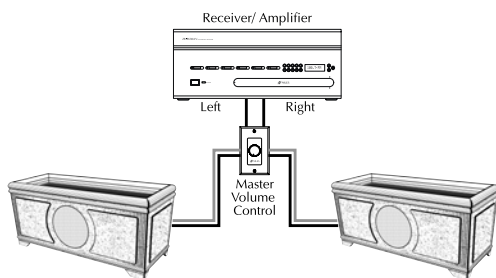

Figure 3. Two-speaker stereo, one zone volume control wiring

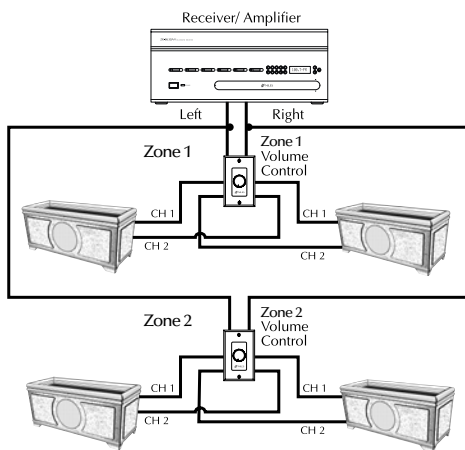

Figure 4. One-speaker stereo, two zone volume control wiring

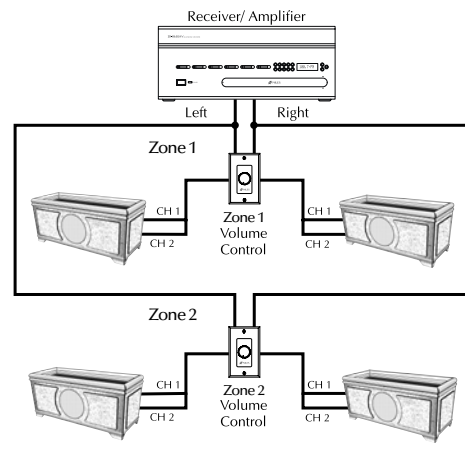

Figure 5. Two-speaker stereo, two zone volume control wiring

CONNECTING THE LOUDSPEAKER IN TWO-SPEAKER STEREO MODE

- Strip two to three inches of each speaker cable's outer jacket away from the insulated conductors. Ensure that at least two inches of the separate conductors are free.
- Strip one half inch of insulation from the end of each conductor for both connection cables.
- Connect one stripped end of the speaker cable coming from the amplifier to the PB6Si connection cable's red wire of one cable and the PB6Si connection cable's yellow wire. To connect the three wires, twist the stripped ends of the wire together and screw down the wire nut on the twisted wires. The material inside the wire nut will protect the stripped ends of the wire. However, if added protection is desired, place a large amount of silicon sealant so the bottom of the wire nut is encased and sealed. Pay attention to the markings on the speaker cable. Each loudspeaker you connect must be connected to the amplifier's speaker wire in the same way.
- Repeat step 3 with the PB6Si connection cable's black wires and the other stripped amplifier speaker cable's conductor.
- Connect the opposite end of the speaker cable to the amplifier or receiver. Start by performing step 1 and 2 on the speaker cable near the amplifier. Paying attention to the markings on the speaker cable conductor, attach the same conductor you attached to the red loudspeaker wire to the positive (red) or (+) amplifier output terminal. Attach the other conductor to the amplifier's negative (black) or (-) amplifier output terminal.

TROUBLESHOOTING

VERIFY SYSTEM OPERATION AND LOUDSPEAKER COVERAGE

- Turn the system "On" and play music to the speakers. Set the Volume controls to a level that allows the speakers to be easily heard over the "noise" in the area.
- Verify that music is playing through each speaker. If not, troubleshoot the wiring and make sure each speaker is electrically connected to the amplifier.
- Verify that each speaker is connected to the proper channel of the amplifier. To do this, change the balance of your speakers on your amplifier or receiver so that one channel is playing loudly and the other is not. Verify that each speaker or each side of the speaker is attached to the proper channel of the amplifier. If they are not, correct the wiring on the loudspeaker that is not connected properly. Reset the balance on the amplifier or receiver so both channels have a similar volume level.
- If you used a volume control between the amplifier and the speakers, verify that it is controlling the volume of the loudspeakers in its zone. Repeat this for every volume control in the system. If it is not, correct the wiring.
- Position the loudspeakers per the layout and verify that the sound is even and consistent throughout the area.